

Table of Contents

SECTION 01 10 00 — APPLICATION OF SPECIAL PROVISIONS	2
SECTION 01 25 00 — SUBSTITUTIONS.....	6
SECTION 01 26 00 — REQUESTS FOR INFORMATION	10
SECTION 01 30 00 — ADMINISTRATIVE REQUIREMENTS.....	13
SECTION 01 31 19 — COORDINATION AND MEETINGS.....	20
SECTION 01 32 00 — SCHEDULES.....	26
SECTION 01 33 00 — SUBMITTALS.....	39
SECTION 01 35 20 — PERMITTING.....	49
SECTION 01 35 23 — GENERAL SAFETY PROVISIONS.....	52
APPENDIX 01 35 23 A CRANES, HOISTS, AND RIGGING.....	87
SECTION 01 35 23 19 — ASBESTOS SAFETY — CLASS III	94
SECTION 01 35 23 21 — LEAD WORK EXPOSURE PROTECTION.....	107
SECTION 01 35 23 23 — RADIOLOGICAL SAFETY CRITERIA.....	118
SECTION 01 35 43 — ENVIRONMENTAL PROTECTION	120
SECTION 01 40 00 — QUALITY REQUIREMENTS.....	136
SECTION 01 42 00 — CODES AND STANDARDS	143
SECTION 01 50 00 — TEMPORARY FACILITIES/CONTROLS AND SITE CLEAN UP	150
SECTION 01 52 00 — STORAGE AND PROTECTION	160
SECTION 01 77 00 — PROJECT CLOSEOUT	162

SECTION 01 10 00 — APPLICATION OF SPECIAL PROVISIONS

PART 1 PURPOSE

These Special Provisions of the MTA provide minimum requirements for the execution of A-E and Construction Management efforts and deliverables under Task Orders. Additional project specific requirements and information from the Participating Sites will be invoked in Task Orders. In the event of a conflict between these provisions and Participating Site-specific requirements, consult the LLNS Technical Representative. Refer to the Task Order Article entitled, “Participating Site-Specific Requirements” for order of precedence.

PART 2 APPLICABILITY

The Subcontractor shall incorporate the direction provided in the sections of these Special Provisions as detailed below either when performing work under the A-E Task Orders or when providing direction to its lower-tier build subcontractors under Construction Management Task Orders.

Section Number	Title	When to Apply
01 25 00	Substitutions	A-E, CM
01 30 00	Administrative Requirements	A-E, CM
01 31 19	Coordination and Meetings	CM
01 32 00	Schedules	CM
01 33 00	Submittals	CM
01 35 20	Permitting	LLNS CM
01 35 23	General Safety Provisions	A-E, CM
01 35 23 19	Asbestos Safety – Class III	CM
01 35 23 21	Lead Work Exposure Protection	CM
01 35 23 23	Radiological Safety Criteria	A-E, CM
01 35 43	Environmental Protection	CM
01 42 00	Codes and Standards	A-E, CM
01 50 00	Temporary Facilities and Site Cleanup	CM
01 45 00	Quality Control	CM
01 52 00	Storage and Protection	CM
01 77 00	Project Closeout	CM

A-E = Architectural and Engineering efforts

CM = Construction Management efforts, must be flown down to lower-tier build subcontractors

LLNS = Applicable to Task Orders for work at LLNL only

PART 3 INTENT AND ARRANGEMENT OF DOCUMENTS

- A. It is intended that these Special Provisions in conjunction with the MTA and Task Order contain everything necessary to perform the work properly. Every item

necessarily required may not be specifically mentioned or shown. All systems and equipment shall be complete and operable unless expressly stated otherwise.

- B. Titles and headings to divisions, sections, and paragraphs in these documents are introduced for convenience and shall not be taken as a correct or complete segregation of the several units of materials and labor. No responsibility either direct or implied is assumed by LLNS or its designated representative for omissions or duplications by the Subcontractor or its subcontractors, due to real or alleged error in arrangement of matter in the documents.
- C. The terms of the MTA and the Task Order apply to each section of these specifications as fully as if repeated within that division.
- D. Items listed under these Special Provisions or sections of the specifications are not necessarily all inclusive. The Subcontractor shall be responsible for performance and completion of the work in accordance with the applicable MTA and Task Order requirements.
- E. Portions of the Special Provisions are of the abbreviated, simplified type and may include incomplete sentences.
 - E.1 Omissions of words or phrases such as “The Subcontractor shall,” “in conformity with,” “shall be,” “as noted on the drawings,” “in accordance with details,” “a,” “the” and “all” are intentional. Omitted words or phrases shall be supplied by inference in the same manner as they are when a “note” occurs on the drawings.
 - E.2 Such terms as “approved,” “approved equal,” “as directed,” “as required,” “as permitted,” “acceptable,” “satisfactory,” mean by or to LLNS.

PART 4 DATA

1.1 ACCURACY OF DATA

- A. The data, Task Order, specifications, and the associated reference drawings are as exact as could be secured, but their absolute accuracy cannot be guaranteed. They are for the assistance and guidance of the Subcontractor and exact locations, distances, levels, and like items will be governed by the work.

- B. Take these data with the understanding that the Task Order, drawings and specifications may be supplemented by more detailed specifications and drawings intended to aid construction without changing the scope or cost of the work. Conform to them without additional cost to LLNS.
- C. Before starting the work, check all lines, levels, and dimensions shown on the drawings against field conditions (reference section 01 31 19 “Coordination and Meetings”). If discrepancies are discovered, report them to the Participating Site Representative at once. In the event of discrepancies, do not proceed with the work until the Participating Site Representative gives direction.

1.2 SURVEY DATA

Where applicable, the Participating Site shall provide drawings with the location of horizontal and vertical control points in the vicinity of the site. The Subcontractor shall ensure transfer of said data to the site for the proper execution of the work.

PART 5 DEFINITION OF TERMS

- A. Application: The definition of terms used in the MTA, Task Order, the drawings, and specifications are as follows and shall apply throughout. For additional definitions, refer to the MTA Statement of Work; for detail concerning roles and responsibilities, refer to section 01 30 00 subpart 1.1.
- B. LLNS: The term “LLNS” shall mean Lawrence Livermore National Security, LLC. LLNS is the lead Management and Operating (M&O) Contractor responsible for ensuring the overall implementation of CHAMP and performing the technical direction, oversight, and subcontracting on behalf of the DOE/NNSA complex.
 - B.1 Contract Analyst: All business matters of a contractual nature pertaining to construction work are directly under the jurisdiction of the LLNS’ Contract Analyst.
 - B.2 LLNS Technical Representative: The individual responsible establishing and program managing the CHAMP collaboration with the Subcontractor and for managing and controlling the construction projects at LLNL and reporting their status and progress.
- C. Subcontractor: The person, company, or corporation responsible for the execution of a Task Order, or any portion thereof, that has been awarded by LLNS. The term “Subcontractor” may refer to any lower- tier subcontractor concerned with the section or division of the Special Provisions or specifications in which the term is used. This in no way relieves the Subcontractor from sole responsibility for completing the entire work as required by the Task Order.

- D. By Others: The work indicated by this term means that the work is not included in this Task Order. The acronym NIC (not included in contract) means “by others.”
- E. Task Order: a subcontract between LLNS and the Subcontractor that is subject to the terms of the MTA. The term “Subcontract” may refer to Task Order or the term “Task Order” may refer to Subcontract.
- F. Furnish, Install, and Provide:
 - F.1 Furnish: Supply and deliver to project site, ready for installation.
 - F.2 Install: Place in position for service or use.
 - F.3 Provide: Furnish and install, complete and ready for intended use.
- G. LLNL or Site 200 or Site 300: LLNS’ Lawrence Livermore National Laboratory (LLNL), east of Livermore, Alameda County, California. Site 300 of the LLNL is located off Corral Hollow Road, ten miles southwest of Tracy, California in San Joaquin County.
- H. Participating Sites: Refer to the MTA Article entitled, “Purpose and Nature of the Master Task Agreement,” for a list of Participating Sites. Within these Special Provisions, the Participating Site refers to the site where the work is performed; this includes LLNL when work is performed at LLNL. Whenever phrases “Participating Site and LLNS” or “Participating Site and LLNL” appear, the subject action or deliverable should be directed both rather than directed exclusively to the site where the work is performed.

END OF SECTION

SECTION 01 25 00 — SUBSTITUTIONS

PART 1 GENERAL

1.1 SECTION INCLUDES

- A. The work specified in this section consists of preparing, submitting, amending, and updating lists of products or materials which the Subcontractor proposes to furnish and install instead of those indicated.
- B. Documentation procedures.
- C. Subcontractor certifications.

1.2 SUBMITTAL PROCEDURES

- A. Substitutes for Specified Items: Wherever catalog numbers and specific brands or trade names followed by the designation “or equal” are used in conjunction with a designated material, product, thing, or service mentioned in these specifications, they are used to establish the standards of quality, utility, and appearance required. Substitutions that are equal in quality, utility, and appearance to those specified will be approved, unless specified “no substitutions.” Substitutions are subject to the following provisions:
 - A.1 Submit all substitutions in writing, for LLNS approval, in addition, copy the Participating Site Representative and LLNS within 14 calendar days after the date of commencement specified in the Task Order Award. Subcontractor’s submission shall include a typewritten list containing a description of each proposed substitute item or material.
 - A.2 Append to this list sufficient data, drawings, samples, literature, or other detailed information as will demonstrate to LLNS that the proposed substitute is equal in quality, utility, physical size, and appearance to the item or material specified.
 - A.3 LLNS and/or the Participating Site will approve, in writing, such proposed substitutions as are determined by LLNS and/or the Participating Site to be equal in quality, utility, and appearance to the items or material specified. Such approval will not relieve the Subcontractor from complying with the requirements of the drawings and specifications, and the Subcontractor shall be responsible at its own expense for any changes resulting from proposed substitutions that affect other parts of its own work or the work of other subcontractors.
 - A.4 Subcontractor failure to submit proposed substitutions for approval in the manner described above and within the time prescribed shall be sufficient cause for disapproval by LLNS of any substitutions otherwise proposed.

- A.5 Wherever catalog numbers and specific brands or trade names not followed by the designation “or equal” are used in conjunction with a designated material, product, thing, or service mentioned in these specifications, no substitutions will be approved.
- A.6 If the use of substitute products or materials involves redesign of other parts of the work, LLNS’ cost for redesign will be charged to the Subcontractor. If this substitution is found to affect the work of others on the project, the cost of this additional work of others will also be charged to the Subcontractor.
- A.7 Submitting a substitution request does not relieve the Subcontractor from schedule commitments. It is the Subcontractor’s responsibility to recognize in a timely manner if materials are not readily available.
- A.8 Incomplete substitution requests may be rejected.
- B. Selection of Alternate Manufacturers: Wherever more than one manufacturer’s product is specified, the first named manufacturer is the basis for the project design and the use of alternative “or equal” manufacturers' products or substitutes may require modifications in the project design and construction. The Subcontractor shall assume costs required to make necessary revisions and modifications including additional costs to LLNS for evaluations of modification of the project design submitted.
 - B.1 When materials are specified by manufacturer’s name and product number, “or equal,” submit manufacturer’s products in accordance with the requirements for substitute items.
 - B.2 LLNS, in review of the list of materials and equipment, requires revisions or corrections to be made or shop drawings and/or supplemental data to be submitted, promptly do so. If any proposed substitute is judged by LLNS to be unacceptable, provide the specified item; further submissions will not be allowed, unless directed by LLNS.
 - B.3 Physical samples may be required. If tests for the determination of quality and utility are required by LLNS, they shall be made by a testing laboratory, with acceptance of the test procedure first given by LLNS, and at the expense of the Subcontractor.

1.3 DOCUMENTATION PROCEDURES

- A. Provide an itemized comparison of proposed substitution to the item specified. Provide, in a tabular form the differences in materials, size, finish, estimated life, estimated maintenance, availability of spare parts and repair services, energy

consumption, performance capacity, salvageability, and manufacturer's warranties. Include the following:

- A.1 Identification of the specification section or detail reference where the proposed substitution applies.
- A.2 Identification of materials, products or supplies, including manufacturer's name, catalog name and number, and the manufacturer's address and telephone number.
- A.3 Installation characteristics, installation drawings and manufacturer's literature, including product description, performance and test data, and reference standards if pertinent.
- A.4 Name and address of projects on which the product was used under similar circumstances, and dates of installation.
- A.5 Effect of change on project schedule. Demonstrate redesign due to substitution will not adversely alter the project schedule.
- A.6 Accurate cost data for the proposed substitution in comparison with the product specified. Provide an itemized list with cost comparisons including labor and materials.
- A.7 Equitable adjustment and credit which the Subcontractor proposes to offer LLNS, including accounting of costs incurred by LLNS due to redesign or evaluation services, increased cost of other LLNS construction, and similar considerations.
- A.8 When applicable or requested by LLNS, provide off-the-shelf samples of the specified item and the proposed substitution.
- A.9 Description of how this substitution impacts other related systems and work of others.

1.4 SUBCONTRACTOR CERTIFICATIONS

- A. Certify the following when making a request for substitution:
 - A.1 The Subcontractor has investigated the proposed item and believes it to be equivalent, or superior, to that shown or specified; and the Subcontractor shall update the information as new or different data becomes known.
 - A.2 The Subcontractor shall furnish the same guarantee for the substitution as for the product specified.

- A.3 The Subcontractor shall coordinate the installation of the accepted substitution into the work, and will make those changes, subject to LLNS approval, required for the work to be complete in all respects.
- A.4 The Subcontractor waives all claims for costs related to the substitution.
- A.5 Cost data are complete.

PART 2 PRODUCTS

Not used

PART 3 EXECUTION

Not used

END OF SECTION

SECTION 01 26 00 — REQUESTS FOR INFORMATION

PART 1 GENERAL

1.1 DEFINITIONS

Request for Information. A document submitted by the Subcontractor requesting clarification of a portion of the subcontract documents. Referred to as an RFI.

1.2 SUBCONTRACTOR'S REQUESTS FOR INFORMATION (RFI)

- A. Request an interpretation from the Site if any of the following applies:
 - A.1 Subcontractor is unable to determine from the subcontract documents the exact material, process, or system to be installed
 - A.2 Elements of construction are required to occupy the same space (interference)
 - A.3 An item of work is described differently in more than one place in the subcontract documents
- B. Prepare and submit RFIs on a standardized form. Completely fill in the RFI form.
- C. Review and attach RFIs from lower-tier subcontracts and suppliers to a new RFI prepared and submitted as described above for Subcontractor-initiated RFIs.
 - C.1 Review lower-tier subcontractor and supplier-initiated RFIs and take actions to resolve issues of coordination, sequencing, and layout of the work.
 - C.2 Subcontractor is responsible for delays resulting from the necessity to resubmit an RFI due to insufficient or incorrect information presented in the RFI.
- D. Before submitting an RFI
 - D.1 Verify the information is not already included in the subcontract documents. LLNS will coordinate with the subcontractor to close RFIs that request information that is clearly indicated in the subcontract documents.
- E. Do not use RFIs for the following purposes.
 - E.1 To request clarification of issues related to means, methods, techniques, and sequences of construction or for establishing trade jurisdictions and scopes of lower-tier subcontracts. Such issues, unless stated otherwise in the subcontract documents, are solely the Subcontractor's responsibility.

- If an RFI impacts the sequence of construction, then note the impact on that RFI for consideration by LLNS and the Site Provide complete information required for LLNS to analyze and understand the circumstances causing the impact.
- E.2 To request approval of submittals (use procedures specified in section 01 33 00, Submittals)
- E.3 To request approval of substitutions (use procedures specified in section 01 25 00, Substitutions)
- E.4 To request subcontract changes such as cost, schedule, design, or work performance. (Use change order procedures in the subcontract documents Indicate that there is a cost impact, but do not put costs in an RFI).
- F. If the Subcontractor believes that a clarification (official response) by LLNS or the design professional results in additional cost or time, do not proceed with the work indicated by the RFI until authorized by LLNS in accordance with the General Provisions of the subcontract.
- G. LLNS will respond to RFIs within 14 calendar days.

PART 2 PRODUCTS

Not used

PART 3 EXECUTION

Not used

END OF SECTION

This page intentionally left blank

SECTION 01 30 00 — ADMINISTRATIVE REQUIREMENTS

PART 1 GENERAL

1.1 RESPONSIBILITIES

- A. The Subcontractor shall:
 - A.1 Provide A-E and Program Management staffing annually as directed by Task Order.
 - A.2 Proceed promptly with the performance of the Task Order and any technical instructions of the nature prescribed in this section and the MTA.
 - A.3 Direct all communications through the Participating Site Representative and the Contract Analyst as appropriate.
 - A.4 Notify the Contract Analyst in writing within 24 hours of receipt, if in the opinion of the Subcontractor, the LLNS Technical Representative or the Participating Site Representative has issued technical instructions or directions to the Subcontractor that exceed the limits of their authority. Do not proceed but request the Contract Analyst to modify the subcontract accordingly.
 - A.5 Supply all construction decisions required relating to the drawings, Special Provisions, specifications, and other construction data furnished to lower tier subcontractors pursuant to the Subcontract or necessary for successful performance of the work.
 - A.6 For oversight of Construction Management Task Orders, the Subcontractor shall provide the following types of support: Construction Management, including Safety Management, and administrative support.
- B. The LLNS Technical Representative will:
 - B.1 Serve as the MTA CHAMP Program Manager and address all matters of a technical nature associated with the MTA and the program.
 - B.2 Provide technical oversight and lead the implementation and execution of systems engineering solutions to enable the management of HVAC assets and conduct annual program reviews.

B.3 Serve as the Participating Site Representative for all work done at the LLNL.

C. The Participating Site Representative will:

C.1 Oversee all aspects of construction activities, including safety, security and schedule, while the Subcontractor and its lower-tier subcontractors are performing work at the Participating Site.

C.2 Supply construction decisions required to the Subcontractor relating to the drawings, Special Provisions, specifications, and other construction data furnished to the Subcontractor pursuant to the subcontract or necessary for successful performance of the work.

C.3 Review and coordinate with other Participating Site stakeholders the internal review and approval of site-specific safety, schedule and technical submittals for accuracy, currency, completeness and compliance with the requirements of the MTA and the applicable Task Order.

C.4 Monitor the Subcontractor's safety program for compliance with subcontract requirements and other applicable codes and regulations, and assume responsibility for general surveillance over the implementation of security and safety procedures.

C.5 Participate in the initiation and preparation of technical changes in the applicable drawings, specifications, and other construction data.

C.6 Provide quality assurance oversight of work in progress.

C.7 Authorize and require the Subcontractor to correct defects discovered in partially or fully completed construction work.

C.8 Review for accuracy and completeness and forward for LLNS approval, Subcontractor invoices for payment based upon percentage of completed work.

C.9 Render decisions in the areas designated herein. The Subcontractor shall refer questions, submittals, and like items, in these designated areas to the Participating Site Representative. Neither the rights of general supervision, direction, inspection, review, comment, or approval conferred on the Participating Site Representative, nor its exercise of these rights, shall relieve the Subcontractor from any obligations set forth in the subcontract documents.

C.10 Coordinate the efforts of the Subcontractor and its lower-tier

- subcontractors with Site personnel and facility, including scheduling and interface between Participating Site personnel and subcontractors.
- C.11 Conduct weekly construction meetings, coordination meetings, and pre-installation meetings as defined in section 01 31 19 “Coordination and Meetings.”
 - C.12 Issue written technical instructions within the scope of work stated in the subcontract.
 - C.13 Evaluate change order proposals and provided recommendations and technical analysis to the LLNS Contract Analyst.
 - C.14 Coordinate all permits, outages, safety inspections, hazardous waste disposal, and other site interface activities with the Participating Site.
- B. Limits of Participating Site Representative Authority: The Participating Site Representative will not issue technical instructions or directions, either oral or in writing, which would:
- C.1 Constitute an assignment of work outside the general scope of the work covered by this subcontract or the construction management task order; or
 - C.2 Increase or decrease the price for performance of the work or the time required for performance of the work covered by this subcontract or the construction management task order; or
 - C.3 Execute any end-use certificates or representations; or
 - C.4 Change any express term or condition of the subcontract or the construction management task order; or unreasonably interfere with the Subcontractor's ability to perform and complete the work, as required under the subcontract or construction management task order. The term “unreasonably” shall be quantifiable by either time or cost.
- C. The Contract Analyst will:
- C.1 Conduct all business matters of a contractual nature and all administrative duties associated with the MTA and Task Orders;
 - C.2 Process all formal changes to the MTA and Task Orders as required and any end-use certifications or representations;
 - C.3 Negotiate adjustments or changes in the price, schedule, terms, conditions, or provisions of the MTA and Task Orders with the Subcontractor as the sole LLNS’ Representative authorized to effect binding changes.

- C.4 Authorize any technical instruction from the Participating Site Representative by issuing a written modification to this MTA or any Task Order.

1.5 SITE STAFFING AND WORK HOURS (APPLICABLE TO CM TASK ORDERS ONLY)

- A. Site Staffing: As a minimum, the Subcontractor shall ensure the lower-tier build subcontractor provides staff positions for the following:
 - A.1 Construction Superintendent: The construction superintendent shall be in residence at the jobsite at all times, including overtime hours and shift work hours, when work is being performed by the Subcontractor or its lower-tier subcontractors. If the Subcontractor's superintendent leaves the jobsite while work is being performed, the Participating Site Representative will stop all work. Any costs that the Subcontractor might incur due to said stoppage will be solely at the Subcontractor's expense. The construction superintendent shall be responsible for assuring work is performed in accordance with all Task Order requirements and effectively directing and coordinating all trades to assure safe and efficient progress of the work. The construction superintendent shall be knowledgeable of the project's requirements and hazards and have full authority to act on behalf of the Subcontractor. The construction superintendent shall make frequent and regular inspections of the construction jobsite to identify and correct any instances of noncompliance with requirements. During the periodic absences of the Safety Officer, the Construction Superintendent may serve as the Safety Officer, provided he or she does not perform construction work during the same timeframe.
 - A.2 Quality Control Manager: The quality control manager can be a corporate resource that oversees work on this project on a part-time basis and can delegate full-time responsibility to other individuals.
 - A.3 Safety Officer:

The Safety Officer shall be in residence at the jobsite at all times, including overtime hours and shift work hours, when work is being performed by the Subcontractor or its lower-tier subcontractors. If the Subcontractor's superintendent leaves the jobsite while work is being performed, the Participating Site Representative will stop all work. Any costs that the Subcontractor might incur due to said stoppage will be solely at the Subcontractor's expense. The construction superintendent shall be responsible for assuring work is performed in accordance with all Task Order requirements and effectively directing and coordinating all trades to assure safe and efficient progress of the work. The construction

superintendent shall be knowledgeable of the project's requirements and hazards and have full authority to act on behalf of the Subcontractor. The Safety Officer shall make frequent and regular inspections of the construction jobsite to identify and correct any instances of noncompliance with requirements. During the periodic absences of the Safety Officer, the Construction Superintendent may serve as the Safety Officer, provided he or she does not perform construction work during the same timeframe.

B. Work Hours (Unless otherwise defined in the Task Order):

B.1 Standard work hours are Monday through Friday from 7:00 a.m. to 6:00 p.m. excepting holidays consistent with the Participating Site's typical construction working schedule; 40 hours per week scheduling for Subcontractor personnel.

B.2 Submit requests for nonstandard work hours to the Participating Site Representative at least 72 hours in advance.

1.6 SALVABLE AND EXCESS MATERIALS (APPLICABLE TO CM TASK ORDERS ONLY)

A. Do not use salvable material dismantled from existing work in new construction unless specifically indicated otherwise in the Task Order.

B. All materials noted to be dismantled, and reinstalled shall be dismantled and stored in such a manner to prevent damage. The Subcontractor is responsible for the condition of these materials until they are reinstalled and accepted by the Participating Site Representative.

C. All materials noted to be dismantled, salvaged, and to remain the property of the Participating Site shall be stored in such a manner as to prevent damage. The Subcontractor is responsible for the condition of these materials until accepted by the Participating Site Representative.

D. All other materials dismantled from existing work and released through the Participating Site Representative to the Subcontractor shall become the Subcontractor's property. Immediately remove these materials from the Participating Site.

1.7 EMERGENCY REPAIRS (APPLICABLE TO CM TASK ORDERS ONLY)

The Participating Site reserves the right to make emergency repairs as required to keep equipment in operation without voiding the Subcontractor's guarantee or relieving the Subcontractor of its responsibilities.

1.8 PARTIAL OCCUPANCY OR USE (APPLICABLE TO CM TASK ORDERS ONLY)

- A. The Participating Site may reserve the right to occupy any completed or partially completed portion of the work provided that LLNS and the Subcontractor have accepted, in writing, the responsibilities assigned to each of them for payments, retainage, if any, security, maintenance, utilities, damage to the work, insurance and the period for correction of the work and commencement of warranties required by the Task Order for such portions of the work partially used or occupied.
- B. In the event the Subcontractor and LLNS are unable to agree upon the matters set forth above, the Participating Site may nevertheless use or occupy any completed or partially completed portion of the work. Immediately prior to such partial occupancy or use of the work, or portions thereof, the Participating Site Representative and the Subcontractor shall jointly inspect the portions of the work to be occupied or to be used to determine and record the condition of the work.

1.9 FINAL ACCEPTANCE (APPLICABLE TO CM TASK ORDERS ONLY)

- A. Provide written notice to the Participating Site Representative when the work is ready for final inspection and acceptance, stating that the Subcontractor has carefully inspected all portions of the work, has reviewed in detail the drawings and specifications and, that to the best of the Subcontractor's knowledge, all contractual requirements have been fulfilled. Provide as-built drawings prior to the request for final inspection.
- B. Upon receipt of this notice, the Participating Site Representative, with Subcontractor's cooperation, will conduct joint reviews, inspections and tests as may be reasonably required to satisfy the Participating Site Representative that the work, or identified portion of the work, conforms to all requirements of the Subcontract. Subcontractor shall track and complete outstanding or incomplete work items (punch list items) identified by the Participating Site Representative and / or the Subcontractor. Subcontractor shall provide input on punch list items to the Participating Site Representative using approved forms. Data may be collected via hard copy, electronic format (Word or Excel) as determined by the Participating Site Representative. After deficiencies, if any, have been corrected or accounted for, the punch list should be initialed by both parties. Then, the Participating Site will verify the Subcontractor has resolved all punch list items and provided compliant and complete technical submittals to support final acceptance.

PART 2 PRODUCTS

Not used

PART 3 EXECUTION

Not used

END OF SECTION

SECTION 01 31 19 — COORDINATION AND MEETINGS

PART 1 GENERAL

1.1 SECTION INCLUDES

- A. Coordination and project conditions
- B. Field engineering
- C. Preconstruction meeting
- D. Coordination meetings
- E. Pre-installation meetings

1.2 COORDINATION AND PROJECT CONDITIONS

- A. Coordinate and schedule the work of all tiered subcontractors, and provide all information required by them for proper scheduling and execution of the work. In the same manner, the Subcontractor shall coordinate its work with that of the Participating Site and any other Subcontractor(s) operating in the area, including reasonable adjustments of schedule in order to allow other Subcontractor(s) or the Participating Site to do their work.
- B. Verify that utility requirements and characteristics of operating equipment are compatible with building utilities supplied and installed by others. Coordinate work of various sections having interdependent responsibilities for installing, connecting to, and placing in service, such equipment.
- C. Routing and Coordination of Installations:
 - C.1 Schedule and coordinate the work of all tiered subcontractors having installation responsibilities both with respect to the sequence of work and the allocation of space for routing among the trades. The Subcontractor's accepted construction project schedule shall clearly indicate the planned sequence of work in such areas and any proposed departure from it affecting or potentially affecting coordination of the overall installation shall be brought promptly, in writing, to the attention of LLNS and the Participating Site Representative.
 - C.2 When requested in the Task Order, prepare or have prepared detailed shop drawings in plan view, with cross-sections as necessary, indicating proposed installation plans. These drawings shall depict actual elevations and linear dimensions, and all routing changes, transitions, and major offsets deemed necessary to accomplish the installation. Individual shop

drawings may be prepared for each trade working within the designated space or area; however, the coordination of the consolidated installation shall remain the responsibility of the Subcontractor.

- C.3 Submit these shop drawings to the Participating Site Representative for review prior to commencement of installation and provide copies to each installer having work in the area.
 - C.4 Should unavoidable conflicts be encountered during the preparation or review of the shop drawings, or during construction, promptly bring them to the attention of the Participating Site Representative, in writing, for resolution.
 - C.5 Where the drawings are diagrammatic, showing only the general arrangement of the systems, fit materials and equipment to other parts of the equipment and make adjustments as necessary or required to resolve space problems and preserve service room. In the event a major rerouting of a system appears necessary, prepare and submit for approval, shop drawings of the proposed rearrangement.
 - C.6 Because of the diagrammatic nature and small scale of the drawings, all necessary offsets, adjustments, and transitions required for the complete installation may not be shown. Carefully investigate the structural and finish conditions affecting the work and arrange such work accordingly, providing such fittings, equipment, accessories, and like items, as may be required to meet such conditions, at no increase to the Task Order price.
- D. Coordinate scheduled work with other Subcontractors on jobsite.

1.3 FIELD ENGINEERING

- A. Employ a land surveyor registered in the state in which the Participating Site is located to provide field engineering services.
 - A.1 Establish elevations, lines, and levels, utilizing recognized engineering survey practices.
 - A.2 Verify set-backs and easements; confirm drawing dimensions and elevations.
- B. Submit a copy of the final site drawing signed and certified by the land surveyor that the elevations and locations of the work are in conformance with the subcontract documents.

1.4 PRECONSTRUCTION MEETING

- A. The Participating Site Representative will schedule a meeting after notice of award and prior to Notice to Proceed.
- B. Attendance Required: The Participating Site Representative, Subcontractor, and any tiered subcontractors as required.
- C. Agenda:
 - C.1 Safety submittals and training requirements
 - C.2 Submission of proposed preliminary project schedule
 - C.3 Designation of personnel representing the parties in subcontract
 - C.4 Use of premises by the Participating Site and Subcontractor
 - C.5 LLNS' requirements, the Participating Site's requirements, and partial occupancy
 - C.6 Temporary facilities and controls provided by the Participating Site
 - C.7 Discussion of procedures and processing of field decisions, safety, submittals, substitutions, applications for payments, proposal request, change orders, request for information, and project closeout procedures
 - C.8 Scheduling, sequence of construction, and scheduling of inspection and testing
 - C.9 Surveying
 - C.10 Security and housekeeping procedures
 - C.11 Procedures for maintaining project record documents (as-builts)
 - C.12 Requirements for start-up of equipment
 - C.13 Cybersecurity requirements and use of subcontractor's management software. Use of Subcontractor's cloud services is not allowed unless approved by LLNS in writing.
- D. The Participating Site Representative will record minutes and distribute copies as soon as practical after meeting to each participant and those affected by decisions made.

1.5 COORDINATION MEETINGS

- A. Weekly coordination meetings will be arranged and conducted by the Subcontractor with the Participating Site Representative. The purpose of these meetings will be to discuss progress of the work, jobsite safety, coordination issues between prime Subcontractors, and other pertinent project concerns. The Subcontractor shall be represented by its project manager, site superintendent, safety officer, and lower-tiered subcontractors as required by the Participating Site Representative. Other attendees may include Participating Site personnel who may be affected by the work.
- B. The Subcontractor will make arrangements for meetings, prepare agenda with copies for participants, and preside at meetings.
- C. Agenda:
 - C.1 Project safety
 - C.2 Review minutes of previous meetings
 - C.3 Review of work progress via three-week-look-ahead daily schedule
 - C.4 Field observations, non-conforming work, problems, and decisions
 - C.5 Identification of problems which impede planned progress
 - C.6 Review of submittal schedule and status of submittals
 - C.7 Review of Subcontractor's request-for-information (RFI) log and status outstanding issues
 - C.8 Review requests for substitutions; incomplete RFIs and RFS may be rejected by the Participating Site or LLNS
 - C.9 Review of off-site fabrication and delivery schedules
 - C.10 Maintenance of project schedule
 - C.11 Corrective measures to regain projected schedules
 - C.12 Planned progress during succeeding work period
 - C.13 Coordination of projected progress

- C.14 Maintenance of quality and work standards
- C.15 Effect of proposed changes on project schedule and coordination
- C.16 Other business relating to work
- C.17 Status of change orders
- D. The Subcontractor will record and prepare minutes of the meetings and will distribute copies as soon as practical after meeting to each participant and those affected by decisions made.

1.6 PREINSTALLATION MEETINGS

- A. When required in individual specification sections or as determined by the Participating Site Representative, the Participating Site Representative will convene a pre-installation meeting at the site prior to commencing work of the specified section.
- B. The Subcontractor shall require the attendance of parties directly affecting, or affected by, work of the specific section.
- C. The Participating Site Representative will prepare agenda and preside at meetings to:
 - C.1 Review conditions of proposed installation, preparation, and installation procedures.
 - C.2 Review coordination with related work of other Subcontractors on site.
- D. The Participating Site Representative will record minutes and distribute copies as soon as practical after the meeting to each participant and those affected by decisions made.

PART 2 PRODUCTS

Not used

PART 3 EXECUTION

Not used

END OF SECTION

This page intentionally left blank

SECTION 01 32 00 — SCHEDULES

PART 1 GENERAL

1.1 SECTION INCLUDES

- A. Project schedule Content
- B. Format
- C. Initial schedule submittal and updates
- D. Schedule revisions
- E. Monthly work schedule

1.2 PROJECT SCHEDULE CONTENT

- A. The schedule shall show in detail the planned sequence of all work items and allow for the impact of seasonal and regional climate considerations. This includes design, demolition, fabrication and delivery of structures and equipment, critical submittals, procurement schedule and delivery of long-lead items and equipment, inspections, when the Subcontractor requires government-furnished equipment/material at the jobsite, and planned electrical shutdowns for mechanical and electrical tie-ins. Additionally, the Subcontractor is responsible for obtaining and incorporating relevant holiday and operations information from the Participating Site Representative.
- B. Format:
 - B.1 The Subcontractor's schedule shall clearly identify the critical path. Show complete sequence of construction by activity, with dates for beginning and completion of each element of construction. Show any activity with a duration of greater than or equal to five working days. Show days of travel and site visits that are part of design work. Define activities in sufficient detail and limited duration to allow for ease of tracking.
 - B.2 Activity durations:
 - B.2.1 Identify work of separate stages or phases and other logically grouped activities.
 - B.2.2 Show activity durations for each activity
 - B.3 Clearly identify critical portions of the schedule; use the critical path method (CPM) of network calculations to generate the project schedule

and prepare the project schedule in the precedence diagram method (PDM). The submitted schedule shall take into consideration all milestone dates identified by LLNS.

- B.4 Show accumulated percentage of completion of each item, and total percentage of work completed, as of the first day of each month. Also, provide actual start and finish dates for each activity.
- B.5 Show all lines and columns in all submissions of the schedule.
- B.6 Use Microsoft Project, current version.

1.3 INITIAL SCHEDULE SUBMITTAL AND UPDATES

- A. Initial Submittal: Submit the preliminary project schedule and schedule of values within 7 calendar days of award for review, comment, and coordination with work of separate subcontracts. Incorporate review comments recommended by LLNS.
- B. Project Schedule Updates:
 - B.1 Prepare a three-week look-ahead schedule for use and distribution during the weekly coordination meeting. This schedule shall clearly define all current and projected work for that time frame, including interfaces (e.g., staging, schedule, interferences and like items) with Participating Site special equipment installation and other ongoing construction packages. Identify required inspections. Be prepared to discuss this schedule in detail at the weekly coordination meeting.
 - B.2 Update the project schedule weekly and submit it to LLNS and the Participating Site Representative for review.
 - B.3 LLNS acceptance of the Subcontractor's project schedule does not relieve the Subcontractor of responsibility for the accuracy or feasibility of the schedule or for its ability to meet the subcontract completion date. Such acceptance does not warrant, acknowledge, or admit the reasonableness of durations or logic of the Subcontractor's schedule.

1.4 SCHEDULE REVISIONS

- A. Identify activities modified since previous submittal, major changes in scope, and other identifiable changes. Clearly identify proposed change orders which affect the schedule using a detailed fragnet. Do not make any changes to scheduled milestone dates without prior LLNS approval. Only the Contract Analyst can approve extensions of time.

- B. Provide narrative report to define problem areas, anticipated delays, and impact on schedule. Report corrective action taken, or proposed (including recovery schedules), and its effect including the effect of changes on schedules of separate prime subcontracts. Immediately notify LLNS of any potential sequencing or phasing conflicts with separate prime subcontracts which may arise.
- C. LLNS reserves the right to modify or change the sequencing of activities or utilize float time as needed to benefit the overall project. In the event such changes affect the overall subcontract completion or subcontract amount, the Subcontractor shall not proceed with the change. Instead, the Subcontractor shall follow the procedures outlined in section 01 30 00 "Administrative Requirements," subsection 1.3 A, and request that the Contract Analyst modify the subcontract in accordance with "Change Order Procedures."

1.5 MONTHLY WORK SCHEDULE

- A. The Subcontractor shall also develop a monthly work schedule for all on-site work performed. The schedule shall indicate all periods of weekend and off hour work and show the employees working in those periods.
- B. If changes to work schedules are required during the course of the project, submit a request for approval to the Participating Site Representative at least 10 working days prior to the proposed start of such changes. In no event shall the Subcontractor change approved work schedules without the prior consent of the Participating Site Representative.

1.6 PROJECT SCHEDULE DETAILED REQUIREMENTS

A. Critical Path Method

Use the critical path method (CPM) of network calculations to generate the project schedule. Prepare the project schedule in the precedence diagram method (PDM).

B. Level of Detail

LLNS will consider, but is not limited to, the following characteristics and requirements to determine appropriate level of detail:

C. Activity Durations

- C.1 Reasonable activity durations are those that allow the progress of ongoing activities to be accurately determined between update periods.

- C.2 Ensure that there are no non-procurement and non-level-of-effort activities that have original durations (OD) greater than 30 calendar days.
- C.3 Limit activity duration, except procurement and level-of-effort to no more than 45 calendar days.

D. Design (if design-build project) and Permit Activities

Include design and Subcontractor permit and authorization activities with the necessary meetings and follow-up actions and design package submission dates. Include the design schedule in the project schedule; show the sequence of events involved in carrying out the project design tasks within the specific subcontract period. Identify major design tasks, including those that control the flow of work. Include LLNL review and comment incorporation periods associated with each item.

E. Procurement Activities

Include activities associated with the submittal; LLNL review cycle; acceptance; procurement; fabrication and delivery of long lead materials, equipment, fabricated assemblies; and items on the critical path. A typical procurement sequence includes the following string of activities: submit, accept, procure, fabricate, and deliver.

F. Major Tasks

Include, at least, the following list of tasks, if part of the project scope. Allow 2 weeks for LLNS review and comment:

- F.1 Long lead material deliveries
- F.2 Deliverables as listed in other specification sections
- F.3 Escort support as needed
- F.4 Submission and acceptance of installed equipment lists
- F.5 Submission and acceptance of testing and air balance (TAB)
- F.6 Submission of TAB specialist design review report
- F.7 Construction activities
- F.8 Interfaces with other LLNS operations
- F.9 Planned utility or building service interruptions. If an outage will interfere with LLNS' operations in the affected area, then describe the duration of the interference and the nature of the impact for the STR approval. Identify the

affected buildings and duration of the planned outage. Note that outages may require considerable lead time to arrange; therefore, schedule them as far in advance as possible to avoid delays.

- F.10 Submission and acceptance of testing and balancing of HVAC plus commissioning plans and data
- F.11 Air and water balancing report
- F.12 Commissioning
- F.13 Controls testing plan submission
- F.14 Controls testing
- F.15 Performance verification testing
- F.16 Other systems testing
- F.17 Commissioning (including intermediate systems commissioning)
- F.18 Inspections as defined in section 01 77 00, "Project Close-Out"
- F.19 Correction of punch-list items
- F.20 Close-out

G. LLNS Activities

Show LLNS and other agency activities that could impact progress. These activities include, but are not limited to, acceptances, design reviews, environmental permit approvals by State regulators, permits supplied by LLNS or the Participating Site(s) (see section 01 35 20 Permitting), inspections, utility tie-in, Government-Furnished Equipment (GFE) and notice to proceed (NTP) for phasing requirements.

H. Activity Responsibility Coding (RESP)

Assign responsibility code for activities to the Subcontractor, lower-tier-subcontractors, LLNS, the Participating Site or whoever is responsible for performing the activity. Activities coded with a LLNS/Site code include, but are not limited to, LLNS or Site design reviews, LLNS or Site acceptances, environmental permit approvals by State regulators, government-furnished equipment (GFE) and notice-to-proceed (NTP) for phasing requirements. Code activities not coded with a LLNS or Site responsibility code to the Subcontractor or lower-tier-subcontractor responsible to perform the work. Activities with more than one responsibility code are not allowed. Examples of acceptable activity code values are DOR (for the designer-of-record, ELEC (for the

electrical lower-tier-subcontractor), MECH (for the mechanical lower-tier-subcontractor, and LLNS or Site). Unacceptable code values are abbreviations of the names of lower-tier-subcontractors.

I. Subcontract Changes Coding (MODF)

Assign activity code to activity or sequence of activities added to the schedule because of a subcontract modification or change order, when approved by LLNS, with a subcontract changes code. Key code values to the affected activities. Activity or sequence of activities added to the schedule because of alleged constructive changes made by LLNS may be added to a copy of the current schedule, subject to the acceptance of LLNS. Assign activity codes for these activities with a subcontract changes code. Key the code values to the Subcontractor's numbering system. More than one subcontract changes code per activity is not allowed.

J. Subcontract Work Breakdown Structure Coding (SWBS)

Key code schedule activities to the provided SWBS element as well as to the applicable CSI element [see 3.01.A *Subcontractors Project Schedule*]. Break down the authorized project scope using progressive elaboration to a greater level of definition; from scope statement and work breakdown structure, to logical or related sub elements groupings down to specific scheduled activities to facilitate sufficient planning and invoicing granularity. The Subcontractor may add additional lower levels of detail than the SWBS to better organize their work.

K. Phase of Work Coding (PHAS)

Assign phase of work code to activities based upon the phase of work in which the activity occurs. Code activities to either a design phase or a construction phase. Code fast track design and construction phases proposed by the Subcontractor to allow filtering and organizing the schedule by fast track design and construction packages. If the subcontract specifies construction phasing with separately defined performance periods, identify a construction phase code to allow filtering and organizing the schedule accordingly. Identify each activity with a single project phase and have only one phase of work code.

L. Category of Work Coding (CATW)

Assign category of work code to activities based upon the category of work to which the activity belongs. Category of work code must include, but is not limited to design, design submittal, design reviews, review conferences, permits, construction submittals, construction submittal acceptances, acceptance, procurement, fabrication, delivery, weather sensitive installation, non-weather sensitive installation, start-up, test and turnover. Assign a category of work code to each activity.

M. Scheduled Project Completion and Activity Calendars

The schedule interval extends from award date to the required subcontract completion date. The subcontract completion activity ("End Project") is based on the required subcontract duration in the accepted subcontract proposal, as adjusted for approved subcontract time extensions. The first scheduled work period is the day after award is acknowledged by the Subcontractor. Schedule activities on a calendar to which the activity logically belongs. Activities may be assigned to a 7-day calendar when the subcontract assigns calendar day durations for the activity such as an acceptance activity. If the Subcontractor intends to perform physical work less than seven days per week, schedule the associated activities on a calendar with non-work periods identified including weekends and Site holidays. Assign the category of work code "weather sensitive installation" to those activities that are weather sensitive. LLNS will interpret work periods not identified as non-work periods on each calendar as meaning the Subcontractor intends to perform work during those periods.

N. Project Start Date

Start the schedule no earlier than the date on which the subcontract was executed. Include as the first activity in the project schedule an activity called "Start Project" (or award). Apply the "ES" (early start) constraint date of zero-day duration to the "Start Project" equal to the date that the NTP was executed.

O. Schedule Constraints and Open-Ended Logic

Constrain completion of the last activity in the schedule by the subcontract completion date. Ensure that when the calculated early finish date of the last activity is later than the subcontract completion date the result of the schedule calculations is negative float. Include as the last activity in the project schedule an activity called "End Project". Ensure that the "End Project" activity has a late finish ("LF") constraint date equal to the subcontract completion date for the project, and with a zero-day duration or by using the "project must finish by" date in the scheduling software. No constrained dates other than those specified in the subcontract are allowed. The use of artificial float constraints such as "zero free float" or "zero total float" are prohibited. Only two open-ended activities are allowed: "Start Project" (or award) with no predecessor logic and "End Project" with no successor logic. Activities must have a predecessor and a successor with no dangling activities.

P. Interim Completion Dates

Constrain contractually-specified interim completion dates, using soft constraints, to show negative float when the calculated early finish date of the last activity in that phase is later than the specified interim completion date.

Q. Out-of-Sequence Progress

Activities that have progressed before preceding logic has been satisfied (out-of-sequence progress) is not allowed. Propose logic corrections to eliminate out-of-sequence progress. Use retained logic, not progress override, to correct out-of-sequence logic prior to submitting status.

R. Negative Lags and Start to Finish Relationships

Negative value lag durations contained in the project schedule are not allowed. Do not use start to finish (SF) relationships.

S. Calculation Mode

Retain the logic between predecessors and successors schedule calculations even when the successor activity starts, and the predecessor activity has not finished. Software features that in effect sever the tie between predecessor and successor activities when the successor has started, and the predecessor logic is not satisfied ("progress override") is not allowed.

T. Milestones

The schedule must include milestone activities for each significant project event. Examples of design milestones are: schematic design phase completed, design development phase completed, and construction documents phase completed. Examples of construction milestones are: notice-to-proceed, permits acquired, long-lead items acquired, foundation/substructure construction completed, construction completed, commissioning completed, and beneficial occupancy

U. Total Float

Total float must be less than 2 reporting periods.

V. Weather

Include time for anticipated delays attributable to weather based upon average climatic range provided by the National Weather Service or another approved source.

Include as a weather delay buffer at the end of construction, but prior to subcontract construction completion milestone. Unanticipated delays may be due to unusually severe weather with adverse/delay impact. This delay must be documented in daily reports (see section 01 33 00, Submittals for daily report details) and substantiated with measured and validated data

1.7 PROJECT SCHEDULE SUBMISSIONS

Provide the submissions as described below. The data, Gantt charts, reports, and network diagrams required for each submission are described in the article Submission Requirements.

A. Initial Project Schedule Submission

Submit the initial project schedule for acceptance within 14 calendar days of award. Demonstrate a sequence of activities that represent work through the entire subcontract performance period. Include in the design-build schedule detailed design and permitting activities, including, but not limited to, identification of individual design packages; design submission, reviews and conferences; subcontractor permit and authorization submissions and required LLNS or Site actions; and long lead item acquisition prior to design completion. Also cover in the preliminary design-build schedule the entire construction effort with as much detail as is known at the time; however, as a minimum, include construction start and completion milestones and detailed construction activities through the dry-in milestone, including activity coding and cost loading. Reconcile cost-loaded activities with the subcontract schedule-of-values. Include the remaining construction, including cost loading, but it may be scheduled summary in nature. As the design proceeds and design packages are developed, fully detail the remaining construction activities concurrent with the monthly schedule updating process. Constrain construction activities by LLNS acceptance of associated designs. When the design is complete, update the construction schedule and resubmit.

B. Design Package Schedule Submission

With each design package submitted to LLNS, submit a frag-net schedule extracted from the then current Preliminary, Initial or Updated schedule that covers the activities associated with that Design Package including construction, procurement and permitting activities.

C. Periodic Schedule Updates

Based on the result of the meeting, specified in Periodic Schedule Update Meetings, submit periodic schedule updates, along with invoice and accruals. These submissions will enable LLNS to assess Subcontractor's progress. Update the schedule to include detailed, lower WBS level construction activities as the design progresses, but not later than the submission of the final, un-reviewed design submission for each separate design package. LLNS may require submission of detailed schedule activities for distinct construction that is started prior to submission of a final design submission, if such activity is authorized.

1.8 SUBMISSION REQUIREMENTS

Submit the following items for the Initial Schedule, and every Periodic Schedule Update throughout the life of the project:

A. Data

Provide baseline and current working status file data containing the project schedule in the backup format. Include previous update backup files. Label each submittal indicating the type of schedule (e.g., initial or update), full subcontract number, data date, and file name. Provide each schedule with a unique file name. Submit as required in section 01 33 00, "Submittals."

B. Approved Changes Verification

Include only those project schedule changes in the schedule submission that have been previously approved by LLNS. Specifically reference in the narrative report on an activity-by-activity basis, changes made since the previous period and relate each change to documented, approved schedule changes.

1.9 PERIODIC SCHEDULE UPDATE MEETINGS

Conduct monthly (unless directed otherwise in the PRD) schedule update meetings for the purposes of reviewing the Subcontractor's proposed out of sequence corrections, determining causes for delay, correcting logic, maintaining schedule accuracy. Meetings must occur by the fifth working day of the calendar month and after the Subcontractor has updated the schedule with LLNS concurrence respecting actual start dates, actual finish dates, remaining durations and percent complete for each activity it intends to status. Bring a laptop computer with the scheduling software loaded for the meeting which allows meeting participants to view the proposed schedule update during the meeting. The meeting and resultant acceptable schedule update must be a condition precedent to a formal submission of the update as described in Submission Requirements and to the submission of an invoice for payment. The meeting will be a working interactive exchange that will allow LLNS and the Subcontractor the opportunity to review the updated schedule on a real time and interactive basis. Organize, sort, filter and schedule the update as requested by LLNS. Submit a rough draft of the proposed activity logic corrections to the LLNS STR 48 hours in advance of the meeting. The Subcontractor's project manager and authorized scheduler must attend the meeting.

A. Update Submission Following Progress Meeting

Submit a complete update of the project schedule containing accepted progress, revisions, and adjustments, pursuant to paragraph *Submission Requirements* not later than 4 working days after the periodic schedule update meeting, reflecting only those changes made during the previous update meeting.

B. Status of Activities

Update information, including actual start dates (AS), actual finish dates (AF), remaining durations (RD), and percent complete are subject to the acceptance of LLNS prior to the meeting. As a minimum, address the following items on an activity-by-activity basis during each progress meeting.

C. Start and Finish Dates

Accurately show the status of the AS and AF dates for each activity currently in-progress or completed since the last update. Only assign AS dates when actual progress occurs on an activity.

D. Remaining Duration

Update the estimated RD for incomplete activities independent of percent complete. Remaining durations may exceed the activity OD or may exceed the activity's prior update RD if the LLNS STR considers the current OD or RD to be understated based on current progress, insufficient work crews manning the job, unrealistic OD, or deficiencies that must be corrected that restrain successor activities.

E. Percent Complete

Use physical percent complete. Update the percent complete for each activity started, based on the realistic objective measurable assessment of earned value. Activities that are complete except for remaining minor punch list work and that do not restrain the initiation of successor activities may be declared 100 percent complete. To allow for proper schedule management, cost-load correcting the punch list from LLNS pre-final inspection activities not less than 1 percent of the total subcontract value, which activities may be declared 100 percent complete upon completion and correction of punch list work identified during LLNS pre-final inspections.

1.10 WEEKLY COORDINATION MEETINGS

- A. LLNS and the Subcontractor must meet weekly between the meetings described in paragraph Periodic Schedule Update Meetings in section 01 31 19, "Coordination and Meetings" for jointly reviewing the actual progress of the project as compared to the as planned progress and to review planned activities for the upcoming two weeks. The then current and approved schedule update must be used for the purposes of this meeting and for the production and review of reports
- B. Provide a Gantt chart produced by the scheduling software, organized by total float and sorted by early start date, and a three week "look-ahead" schedule by filtering schedule activities to show only current ongoing activities and activities schedule to start during the upcoming two weeks, organized by work area code

and sorted by early start date. Also show the status of the prior week tasks – one week look-back.

- C. LLNS and the Subcontractor must jointly review the schedules. If it appears that activities on the longest path(s), which are currently driving the calculated completion date (driving activities), are not progressing satisfactorily, and therefore could jeopardize timely project completion, corrective action must be taken immediately. Corrective action includes, but is not limited to, the following: increasing the number of work crews; increasing the number of work shifts; increasing the number of hours worked per shift; and determining if activities coded as LLNS responsibility require LLNS corrective action.

1.11 DIRECTED CHANGES

If issued a directed change order (DCO) for work prior to settlement of price and/or time, submit proposed schedule revisions to LLNS within two weeks of the DCO being issued. LLNS will accept proposed revisions to the schedule prior to inclusion of those changes within the project schedule. The Subcontractor must include these revisions in the project schedule until revisions are submitted, and final changes and impacts have been negotiated. If the Subcontractor has objections to the revisions furnished by LLNS, advise LLNS within two weeks of receipt of the revisions. Regardless of the objections, the Subcontractor must continue to update the schedule with LLNS's revisions until an agreement in the revisions is reached. If the Subcontractor fails to submit alternative revisions within two weeks of receipt of LLNS's proposed revisions, the Subcontractor will be deemed to have concurred with LLNS's proposed revisions. The proposed revisions may be the basis for an equitable adjustment for performance of the work.

1.12 OWNERSHIP OF FLOAT

Float is not for the exclusive use of either LLNS or the Subcontractor; it is jointly owned by both and is a resource available to and shared by both parties as needed to meet subcontract milestones and the subcontract completion date. The use of resource leveling, or other techniques used for artificially adjusting activity durations to consume float and influence critical path is prohibited. Do not sequester shared float through such strategies such as extending activity duration estimates to consume available float, using preferential logic, or using extensive crew/resource sequencing, constraints, unnecessary milestones, leads or lags on logic ties, and hammock type activities.

PART 2 PRODUCTS

Not used

PART 3 EXECUTION

Not used

END OF SECTION

SECTION 01 33 00 — SUBMITTALS

PART 1 GENERAL

1.1 SECTION

- A. Construction Submittal Procedures: General procedures, design/shop drawings and product data, calculations, and manufacturer's written instructions. For direction concerning A-E submittals refer to the MTA Statement of Work.
- B. Samples.
- C. Daily reports.
- D. Test reports and design data.
- E. Certificates.
- F. Manufacturer's field reports.
- G. Erection drawings.
- H. Submittals register.
- I. Administrative submittals

2.1 SUBMITTAL PROCEDURES

- A. General Procedures:
 - A.1 The Subcontractor shall be responsible for managing the submittal review process between the Participating Site and any lower-tier subcontractors. Submit drawings, product data (including material specifications and data sheets), manufacturer's instructions, maintenance manuals, and other submittals specified electronically. Check the correctness of all submittal documents, including those of lower-tier subcontractors prior to submitting them to the Participating Site Representative. If the Subcontractor's submittal is found to be incomplete or unacceptable, the Participating Site Representative will return it to the Subcontractor as "incomplete." Immediately resubmit a complete and acceptable submittal to the Participating Site by the second submission.
 - A.2 Establish a schedule and procedure for the submittals that will ensure their timely submittal, review, and approval or review, return, and resubmittal. Identify critical submittals and shop drawings on the schedule.

No delay will be allowed in the progress of the job attributable to Subcontractor failure to make required submittals per the approved project schedule and submittal register (see subpart 1.9 "Submittal Register"). Advise the Contract Analyst and the Participating Site Representative of any submittal that may be delayed and provide a recovery schedule.

Do not begin any work related to or impacted by any submittal until said submittal has been approved, or written direction to proceed has been received from the Participating Site Representative.

- A.3 Drawings and data, whether prepared by the Subcontractor or its suppliers, shall be submitted as the instruments of the Subcontractor. Therefore, prior to submittal, the Subcontractor shall ascertain that equipment and/or materials covered by submittals meet all requirements of subcontract drawings and specifications and conform to structural and space conditions.
- A.4 Each submittal shall contain literature and identification for each separable and separate piece of material or equipment, with respect to job title, subcontract number, section number, and the specific paragraph of the specifications under which the item is to be provided. Submittals shall be numbered consecutively for each different submittal.
- A.5 Provide space on all shop drawings and submittals for Subcontractor and review stamps.
- A.6 Distribution: Submittals shall be provided per distribution instructions in the applicable Task Order.
- A.7 Apply the Subcontractor's stamp, signed or initialed certifying that review, approval, verification of products required, field dimensions, adjacent construction work, and coordination of information is in accordance with the requirements of the work and subcontract documents.
- A.8 Submittal Review:
 - A.8.a The Participating Site will review drawings and data for conformance with the intent of the design. The approval of the drawings or data shall not relieve the Subcontractor from any errors of dimensions, quantities, or other errors, which may develop later. Approval of the aforementioned documents shall not relieve the Subcontractor from responsibility for deviations from the subcontract drawings and specifications unless the Subcontractor, in writing, specifically called attention to the proposed deviations at the time said deviations were submitted

and has received approval for the deviations in writing.

A.8.b The Participating Site's comments and the Subcontractor's required action will be indicated by notation on the submittals or by inclusion in the letter of transmittal. The review comments will generally be classed as follows:

- "APPROVED," "REVIEWED," or "NO EXCEPTIONS TAKEN" Submittals so noted will generally be classed as drawings and data which appear to be satisfactory without requiring correction.
- "APPROVED AS NOTED" This category will cover drawings and data which, with the corrections noted or marked on submittal, appear to be satisfactory and require no further review prior to construction. Revised drawings reflecting corrections shall be provided.
- "REVISE AND RESUBMIT" Submittals so noted will require a corrected resubmittal for one or more of the following reasons. A revised submittal shall be resubmitted and receive Participating Site approval prior to commencement of related work.
- Drawings and data require corrections, as noted, prior to final review.
- Drawings and data are incomplete and require more detailed information prior to final review.
- Drawings and data do not meet the requirement of subcontract documents.
- "REJECTED" A submittal may be rejected if it is not in compliance with the subcontract documents, or if it proposes an "or equal" substitution without following the proper procedures or documentation. A superseding submittal shall be resubmitted and receive Participating Site approval prior to commencement of related work.

A.9 Return of Submittals:

A.9.a The Participating Site Representative will return marked submittals to the Subcontractor within 7 calendar days. Note that timely reviews are dependent upon complete submittals in strict accordance with these instructions.

- A.9.b An electronic copy of the drawings and data will be returned to the Subcontractor with appropriate stamps and notations. When directed, make indicated changes and corrections, promptly resubmitting three hard copies or an electronic copy, as many times as required to obtain approval.
 - A.10 Subcontractor Resubmittal:
 - A.10.a When revised for resubmission, identify all changes made since previous submission.
 - A.10.b Distribute copies of reviewed submittals to lower-tiered subcontractors as appropriate. Instruct parties to promptly report any inability to comply with requirements.
 - B. Shop Drawings:
 - B.1 Submit shop drawings as required by various sections of these specifications, or as LLNS otherwise requests, for review in accordance with the instruction herein.
 - B.2 Submit shop drawings for proposed rearrangements of equipment and materials, and for substitutions in equipment and materials, which differ from those detailed on the subcontract drawings in accordance with sections 01 31 19 “Coordination and Meetings” and 01 25 00 “Substitutions.” These shop drawings shall be uniform and conform to the subcontract drawings in quality, size, and detail. All costs resulting from such substitutions shall be the Subcontractor's responsibility.
 - B.3 All shop drawings shall be independently checked and signed.
 - C. Design/Shop Drawings:
 - C.1. Submit design/shop drawings as required by various subparts of this section, or as LLNS otherwise requests, for review in accordance with the instruction herein.
 - C.2 Submit design/shop drawings for proposed rearrangements of equipment and materials, and for substitutions in equipment and materials, which differ from those detailed on the subcontract drawings in accordance with sections 01 31 19 “Coordination and Meetings” and 01 25 00 “Substitutions.” These design/shop drawings shall be uniform and conform to the subcontract drawings in quality, size, and detail. All costs resulting from such changes shall be the Subcontractor's responsibility.

- C.3 Drawings shall generally conform to and comply with the U.S. National CAD Standard (NCS) available through the National Institute of Building Science (NIBS). For purposes of these specifications the term "consultant" used in the referenced standards shall mean the Subcontractor or the applicable engineering discipline, as appropriate.
- C.4 All notations, dimensioning and lettering on drawings shall be of a scale to permit legible half-sized reduction. Minimum acceptable sizes are 1/8 inch for handwritten and computer-generated notes, and 1/4 inch for all major labels. Sheet size shall be 22 x 34 inches (D size) or 34 x 44 inches (E size).
- C.5 The drawings shall include one or more title sheets that provide the following:
 - C.5.a Main title for construction package
 - C.5.b List of drawings with Subcontractor drawing number, title, and revision number
 - C.5.c General notes
 - C.5.d Abbreviations
- C.6 All plan drawings shall have a north arrow.
- C.7 All drawings shall have a graphic scale for each scale used on that sheet.
- C.8 The drawing package shall include all drawings needed to provide a full and complete construction package and shall specifically include all drawings specified in this document.
- C.9 All drawings shall be approved and stamped by a professional engineer or architect of the appropriate discipline registered to practice in the state in which the Participating Site is located.

- D. Product Data:
 - D.1 Submit product data as required by various subparts of this section or as LLNS otherwise requests, for review in accordance with the instruction herein.
 - D.2 Product data shall be annotated to clearly indicate make, model, and/or identification numbers of items being submitted for approval.
- E. Calculations (For calculations presented during design, refer to MTA SOW):
 - E.1 Use good form and legible lettering in recording all calculations. Prior to listing the actual calculations, state all known parameters first, along with all references, formulae, assumptions, and constants used. Make all calculations on 8-1/2 x 11-inch computation paper. All calculations shall be project specific and shall be approved and stamped by a professional engineer/architect registered/licensed to practice in the state in which the Participating Site is located. Do not submit generic or "boilerplate" calculations.
 - E.2 Standard, recognized computation techniques, including use of computer codes, shall be used; shortcut methods and rules of thumb are not acceptable. Present the computations in well-indexed document form. The names (not initials) of the engineer/architect shall appear on each handwritten sheet along with the date of origin. Each computation shall be independently checked for reasonableness of result and proper methodology by an engineer/architect having professional credentials (i.e., registered engineer or architect).
- F. Manufacturer's Written Instructions: Where any materials are specified to be installed "according to manufacturer's written instructions," submit three hard copies or an electronic copy of such required instructions at time required in the submittal register. Indicate special procedures, perimeter conditions requiring special attention, and special environmental criteria required for application or installation.

1.13 SAMPLES

- A. Samples for Review: Submit samples to the Participating Site Representative for review for the limited purpose of checking for conformance with information given and the design concept expressed in the subcontract documents.
- B. Samples for Information: Submit samples to the Participating Site Representative for information only.

- C. Samples for Selection:
 - C.1 Submit samples to the Participating Site Representative for aesthetic, color, or finish selection.
 - C.2 Submit samples of finishes from the full range of manufacturers' standard colors, textures, and patterns for selection and verification of quality and utility.
 - C.3 After review, produce duplicates of selections and distribute in accordance with subpart 1.02 above.
- D. Submit samples to illustrate functional and aesthetic characteristics of the product, with integral parts and attachment devices. Coordinate sample submittals for interfacing work.
- E. Include identification on each sample, with full project information.
- F. Submit the number of samples specified; one sample will be retained by the Participating Site.
- G. Reviewed samples which may be used in the work
- H. Samples will not be used for testing purposes unless specifically stated in the specification section.

1.14 DAILY REPORTS

- A. Submit one copy of construction daily reports to the Participating Site Representative at the end of each business day.
- B. Include current activities in progress and areas worked, crew sizes by craft, weather conditions for that day, tests and inspections which occurred that day, and major equipment and material deliveries, and a summary of quality problems, non-conformances and resolutions, when applicable.
- C. Submit copies of pre-task safety planning reports on a daily basis as required in the approved safety plan.

1.15 TEST REPORTS AND DESIGN DATA

- A. Submit for Participating Site review.
- B. Submit test reports and design data for assessing conformance of tested items/components with the design concept expressed in the subcontract documents.

1.16 CERTIFICATES

- A. When specified in individual specification sections, submit certification by the manufacturer, installation/application subcontractor, or the Subcontractor to the Participating Site Representative, in quantities specified for product data for review. Certificates may be recent or previous test results on material or product, but Participating Site approval is required.
- B. Indicate material or product conforms to or exceeds specified requirements. Submit supporting reference data, affidavits, and certifications as appropriate.

1.17 MANUFACTURER'S FIELD REPORTS

- A. Submit reports to the Participating Site Representative for review in duplicate within 7 calendar days of observation.
- B. Review for the limited purpose of assessing conformance with information given and the design concept expressed in the subcontract documents.

1.18 ERECTION DRAWINGS

- A. Submit drawings to the Participating Site Representative for review for the limited purpose of assessing conformance with information given and the design concept expressed in the subcontract documents.
- B. Data indicating inappropriate or unacceptable work may be subject to rejection.

1.19 SUBMITTAL REGISTER

Submit, within 5 calendar days of Notice to Proceed, a comprehensive submittals register. (See sample submittal register in appendix B). This listing shall not be construed as limiting the type and number of Subcontractor submittals, which may be required or advisable in order to facilitate the correct execution of the work. Further description of required submittals shall be as stated in other specification sections. Additional submittals include such items as mockups, installer qualifications, calculations, certifications, and other submittals not specifically categorized.

1.20 ADMINISTRATIVE SUBMITTALS

- A. Submit within 3 calendar days after the notice of award, a list of the Subcontractor's lower tier subcontractors. Include subcontractors' telephone numbers and addresses.

- B. Various sections of the Special Provisions list submittal requirements of administrative nature, as listed in table 01 33 00-1, below. Unless specifically indicated otherwise, submit these using the same process as specified for other submittals in this section.

TABLE 01 33 00-1: ADMINISTRATIVE SUBMITTALS	
SECTION	DESCRIPTION OF SUBMITTAL
01 25 00	Typewritten list containing a description of each proposed substitute item or material
	Documentation showing proposed substitute is equal to specified
	Samples
	Supporting documentation
	Subcontractor certifications
01 31 19	Copy of final site drawing signed and certified by land surveyor
01 32 00	Project schedules
	Work statement (with each progress schedule)
	Look-ahead schedule and updates
01 33 00	Comprehensive submittal register (see appendix B for form)
	Shop drawings or design/shop drawings
	Product data
	Manufacturer's written instructions
	Maintenance manuals
	Calculations and computation techniques
	Samples
	Daily reports
	Test reports and design data
	Certificates (if applicable)
	Manufacturer's field reports
	Erection drawings
01 35 20	Special permits and proof that AHJ has been notified (if applicable)
01 35 23	Description of accident prevention program
	Injury, accident, fire, property damage report for past two years
	Site-specific work plan, including task-specific safety plans
	Job Hazard Analysis or Participating Site Equivalent of this submittal

TABLE 01 33 00-1: ADMINISTRATIVE SUBMITTALS	
SECTION	DESCRIPTION OF SUBMITTAL
	Name and qualifications of on-site person designated responsible for safety, accident prevention, and fire protection
	Verification that each employee understands the safety plan
	Copies of safety education training certificates for each employee, including NIF training if applicable
	Operations with potential hazardous exposure to workers
	Buried and hidden utilities survey (if applicable)
	Excavation and drilling permit request (if applicable)
	Excavation and trenching plan (if applicable)
	Critical lift plan (if applicable)
01 35 43	Storm water pollution prevention plan (SWPPP) for land disturbance greater than one acre, plus training and qualifications for Subcontractor personnel who write the plan
	Disposal manifests for special waste if applicable
	Solid waste management plan (SWMP)
	Material safety data sheets (MSDS)
	Hazardous material inventory (attachment 01210-2)
01 50 00	48-hour notice of large shipments/deliveries
	Telephone service forms (appendix E) if service is desired
01 77 00	Project record documents
	Draft and final maintenance and materials manuals
	Warranty/guarantee documentation
	Written certification project is ready for final inspection and acceptance
	Written certification project is ready for final inspection and acceptance
	Final application for payment
	Spare parts, maintenance, and extra products as specified

PART 2 PRODUCT

Not used

PART 3 EXECUTION

Not used

END OF SECTION

SECTION 01 35 20 — PERMITTING

PART 1 GENERAL

1.1 INTRODUCTION

This section provides information concerning permits for work at the LLNL only. The Subcontractor is responsible contacting the Participating Sites for information concerning their permitting requirements.

1.2 REFERENCES

- A. The following documents form a part of these specifications to the extent stated herein.
- B. State of California, for Participating Sites located in California

California Labor Code Section 7301.1

Bay Area Air Quality Management District (BAAQMD), for Participating Sites located in California

BAAQMD - Asbestos Demolition and Renovation, Regulation 11, Rule 2
- C. National Emission Standards for Hazardous Air Pollutants
Regulation IV (Adopts NESHAP Standards) Rule 4002

1.3 ON-SITE PERMITTING AND AUTHORIZATIONS

- A. General: Permits required for work at LLNL and Site 300 and special permits required for work in particular facilities or within certain areas. LLNS is responsible for obtaining these permits and authorizations on behalf of the Subcontractor, and the Subcontractor is responsible for scheduling the work to allow time to obtain these permits and complying with the requirements of the permits. Refer to the schedule at the end of this section for a general listing of permits issued on site.
- B. Specific Hazard Permits: In addition to general work permits, specific hazard permits may be required.
- C. Modifications or Connections to Existing Utilities: If modifications or connections to the existing utilities (e.g., electric power, water, gas, communications and air) require an interruption of services, give the Participating Site Representative written notice 14 calendar days prior to the desired modification or connection or as defined in the specifications, so a utilities outage permit can be obtained.

1.4 OFF-SITE SPECIAL PERMITTING

A. Although generally, LLNS is not required to secure permits from local jurisdictions for work on site, certain types of work may entail obtaining permits from off-site agencies. Examples include elevator construction, soil remediation due to contamination, closing existing underground water tanks, and other environmentally regulated activities. In such instances, LLNS may be required to obtain the permit, but the Subcontractor may also be required to prepare documentation for the permit. Other permits require the Subcontractor to obtain the permit. In both cases, the Subcontractor shall comply with all regulations regarding the work under the issued permit. Refer to the following paragraphs and the Task Order for a listing of such special requirements.

1.5 OFF-SITE AGENCY NOTIFICATIONS

When the Subcontractor is conducting certain activities on site, off-site agencies having jurisdiction over this work must be notified. Two examples of such an activity are demolition and asbestos-abatement work, which require the Subcontractor to provide at least 10-days prior notification to the local air resource board (BAAQMD or SJVAPCD). Before beginning work that requires off site agency notification, submit proof to LLNS that the agency has received such notification.

PART 2 EXECUTION

2.1 ON-SITE PERMITTING

Refer to the following table 01020-1 for a general listing of on-site permits.

TABLE 01020-1: ON-SITE PERMITTING		
TYPE	DESCRIPTION	REFERENCE
Soil and Excavation	Soil disturbance	01 35 23
Concrete Penetrations”		01 35 23
Hot Work	Thermal heat & spark-producing activities	01 35 23
Utility Outages:		
Fire Sprinkler Outage		
Mechanical Outage		
Low-Voltage Outage		
Energized Electrical Work		
Roof Access		01 35 23
Building/Equipment Drain Outage	Installing, removing, or modifying structure system or component drainage system	

END OF SECTION

This page intentionally left blank

SECTION 01 35 23 — GENERAL SAFETY PROVISIONS

PART 1 GENERAL

The Subcontractor is responsible for coordinating its lower tier subcontractors' compliance with the MTA Special Provisions and the Participating Site-specific safety requirements.

LLNS shall review the Subcontractor's safety plan prior to the award of the MTA. Once approved, the Subcontractor shall be responsible for securing compliance with its plan and additional Participating Site-specific requirements from its lower build subcontractors. This shall be done in accordance with Participating Site Submittal requirements and the deliverables shall cross reference, where applicable, to the approved Subcontractor's Corporate Safety Plan.

1.1 INTEGRATION OF ENVIRONMENT, SAFETY, AND HEALTH (ES&H) INTO WORK PLANNING AND EXECUTION

- A. For the purposes of this section, safety is understood to encompass environment, safety and health, including pollution prevention and waste minimization; and employees is understood to include Subcontractor employees and lower-tier subcontractor employees performing work under this subcontract, and Participating Site employees.
- B. In performing work under this subcontract, the Subcontractor shall work safely; providing a place of employment free from recognized hazards which may cause or are likely to cause death or serious physical harm to employees, including providing protection for the public, and the environment. The subcontractor shall be responsible for the safe performance of the work in accordance with all applicable (state & federal regulatory agencies including this section and Participating Site) ES&H requirements. The Subcontractor shall exercise a degree of care commensurate with the work and the associated hazards. The Subcontractor shall ensure that management of ES&H functions and activities becomes an integral and transparent part of the Subcontractor's work planning and execution processes.
- C. The Subcontractor shall take adequate steps and precautions for the safety of, and shall provide adequate protection to prevent damage, injury, or loss to, the following:
 - C.1 Participating Site or Subcontractor employees involved in the subcontract work and other persons who may be affected.

- C.2 The completed subcontract work in place, incorporated materials and equipment, whether in storage on or off the project site, under care, custody, or control of the Subcontractor or lower-tier subcontractors.
- C.3 Other property that may be present at the project jobsite and other adjoining areas.
- D. The Subcontractor shall, in the performance of work, ensure the following:
 - D.1 Subcontractor line management is responsible for the protection of employees, the public, and the environment. Subcontractor line management includes those Subcontractor and lower-tier subcontractor employees managing or supervising employees performing work.
 - D.2 Clear and unambiguous lines of authority and responsibility for ES&H are established and maintained at all Subcontractor organizational levels.
 - D.3 Subcontractor personnel possess the experience, skills, knowledge, and abilities that are necessary to discharge their responsibilities and Subcontractor shall remove employees from work under the Subcontract if they are determined to be careless, incompetent, unfit for duty or otherwise objectionable to the Subcontractor, LLNS, or the Participating Site.
 - D.4 Resources are effectively allocated to address ES&H considerations for the work performed under this subcontract; and protecting employees, the public, and the environment whenever activities are planned and performed.
 - D.5 Before work is performed, the associated hazards are evaluated and the ES&H standards and requirements contained or referenced in this subcontract, are implemented or fulfilled by the Subcontractor, so as to provide adequate assurance that employees, the public, and the environment are protected from potential adverse consequences of the work to be performed.
 - D.6 Administrative and engineering controls to prevent and mitigate hazards are tailored to the work being performed and associated hazards. Emphasis should be on designing the work and/or controls to reduce or eliminate the hazards and to prevent accidents and unplanned releases and exposures, including the use of personal protective equipment as necessary.
 - D.7 The “conditions and requirements” for initiating and conducting the work are established and agreed-upon by the Participating Site, LLNS, and the Subcontractor. These agreed upon “conditions and requirements” are requirements of this subcontract and binding upon the Subcontractor.

- E. The Subcontractor shall manage and perform the work in accordance with a safety management system (System) documented in a Subcontractor safety plan, that fulfills all conditions in paragraph B above at a minimum. See subpart ~~1.03~~ 1.3 for safety plan requirements.
- F. The System shall describe how the Subcontractor will establish, document, and implement safety performance objectives and commitments. The System shall also describe how the Subcontractor will measure system effectiveness.
- G. The Subcontractor shall comply with, and assist the Participating Site in complying with, ES&H requirements of all applicable laws and regulations, and applicable directives identified in this subcontract.

The Subcontractor shall cooperate with the Participating Site, federal, state, and local agencies having jurisdiction over ES&H matters under this subcontract.

- H. The Subcontractor shall promptly evaluate and resolve any noncompliance with applicable ES&H requirements of this subcontract and the Subcontractor's safety plan. If the Subcontractor fails to provide resolution or if, at any time, the Subcontractor's acts or failure to act cause substantial harm or an imminent danger to the environment or the health and safety of employees or the public, the Participating Site may stop work in whole or in part, and LLNS may follow up with a confirming stop work order. Any stop work order issued by a LLNS Representative under this clause shall be without prejudice to any other legal or contractual rights of LLNS or U.S. Government. In addition, as part of any stop work order, LLNS may, at its discretion, withhold payments and have the Participating Site rescind security access badges, until the Subcontractor submits or implements a satisfactory corrective action plan or cure proposal. In the event that LLNS issues a stop work order, an order authorizing the resumption of the work may be issued at the discretion of LLNS. The Subcontractor shall not be entitled to an extension of time or additional compensation or damages by reason of, or in connection with, any work stoppage ordered in accordance with this clause.
- I. Regardless of the performer of the work, the Subcontractor shall be responsible for compliance with the ES&H requirements applicable to this subcontract and for initiating, maintaining, and supervising all safety provisions, precautions, and programs in the course of the performance of the subcontract.
- J. The Subcontractor shall be responsible for ensuring that its employees and all lower-tier subcontractor employees performing under this subcontract comply with the ES&H requirements applicable to this subcontract. Accordingly, the Subcontractor shall apply the ES&H requirements of this subcontract to all lower-tier subcontractors to the extent necessary to ensure Subcontractor compliance with the ES&H requirements.

The Subcontractor shall include a clause substantially the same as this paragraph in lower-tier subcontracts involving complex or hazardous work. Such subcontracts shall provide for the right to stop work under the conditions described in paragraph 1.2.C.7.e of this section.

- K. The Subcontractor shall provide comprehensive occupational medicine services for its employees (workers) as necessary, in compliance with applicable laws and regulations. LLNS reserves the right to direct, and to review and approve, the specific occupational medicine services provided by the Subcontractor. The Subcontractor shall immediately report to LLNS and the Participating Site Representative any occupational injury, illness, or release of hazardous materials into the environment, associated with performance under this subcontract.

The Subcontractor shall cooperate with LLNS and the Participating Site Representative and provide a written report of the incident (e.g., a first report of injury). This includes allowing LLNS and the Participating Site to review the Subcontractor's logs and summaries of all recordable occupational injuries and illnesses (OSHA No. 300 and 300A Forms or State Equivalent) maintained by the Subcontractor.

- L. The Subcontractor shall allow LLNS and the Participating Site access to all Subcontractor written injury and illness prevention programs (IIPP) established according to the law.
- M. ES&H Performance Feedback: Provide feedback to LLNS when requested, on the effectiveness of LLNS ES&H requirements including, without limitation, those pertaining to on-site ES&H controls, notices, and oversight, LLNS provided ES&H training and information. This feedback may include a self-assessment of the Subcontractor's performance relative to the ES&H requirements of this subcontract.

1.2 SUBCONTRACTOR SAFETY PROGRAM

- A. The Subcontractor is solely responsible for initiating, maintaining, and supervising all safety provisions, precautions, and programs in the course of the performance of the subcontract.
- B. LLNS has established an LLNL Worker Safety and Health Program (LLNL WSHP) implementing the requirement of Subpart C of 10 CFR 851, for all work performed at LLNL jobsites, including work performed by the Subcontractor and its lower-tier subcontractors as have the other Participating Sites. The requirements of the LLNL WSHP pertaining to the Subcontractor and its lower-tier subcontractors are reflected in the following incorporated documents:

B.1 The provisions contained in these specifications,

- B.2 The Subcontractor's approved safety plan, job hazard analysis (JHA), and Subcontractor Area Hazards Control List (SAHCL).
- B.3 When performing work at Participating Sites other than LLNL, the Subcontractor and its lower-tier subcontractors shall implement the WSHP and safety documentation and safety programmatic requirements of the Participating Site.
- C. Management Responsibilities and Worker Rights: The Subcontractor and its lower-tier subcontractors shall provide a workplace that is free from recognized hazards with the potential to cause death or serious physical harm and ensure that work is performed in accordance with these special provisions.
 - C.1 Assign worker safety and health responsibilities, evaluate personnel performance, and hold personnel accountable for worker safety and health performance.
 - C.2 Use qualified worker safety and health professionals (e.g., certified industrial hygienist or certified safety professions).
 - C.3 Provide workers with access to information relevant to the worker safety and health, including:
 - C.3.a The Subcontractor's safety plan, JHA, task-specific safety plans, and any other relevant health and safety documents.
 - C.3.b Applicable injury/illness information from OSHA No. 300 and 300A Forms (or California State equivalents), subject to Freedom of Information Act restrictions.
 - C.3.c Participating Site provided health and safety information and publications.
 - C.3.d Participating Site provided 10 CFR 851 worker's rights poster, to be posted at the jobsite.
 - C.4 Provide measures for workers to report, without reprisal, job-related fatalities, injuries, illnesses, incidents, and hazards and make suggestions for mitigating hazards. Promptly respond to such reports and suggestions.
 - C.5 Provide regular communication with workers about workplace health and safety matters.
 - C.6 Provide procedures that permit workers to stop work or decline to perform tasks they reasonably believe to be dangerous (refer to paragraph 1.2.C.7.e, below).

- C.7 Inform workers of their rights, which include:
 - C.7.a Access to the health and safety information described in 1. 2.C.3, above.
 - C.7.b Notification when monitoring indicates overexposure to hazardous materials.
 - C.7.c Right to observe monitoring and receive the results of their own exposure monitoring.
 - C.7.d Express concerns related to worker safety and health.
 - C.7.e The right to stop work or decline to perform an assigned task based on a reasonable belief that the task poses an imminent risk of death, serious physical harm, or other serious hazard in circumstances where there is insufficient time to use normal hazard reporting procedures.
- C.8 During periods of active construction, the Subcontractor shall have a Safety Officer in accordance with section 01 30 00, 1.3.A.3. The Safety Officer shall be knowledgeable of the project's hazards and have full authority to act on behalf of the Subcontractor. The Safety Officer shall make frequent and regular inspections of the construction jobsite to identify and correct any instances of noncompliance with project safety and health requirements. An additional duty of the Safety Officer shall be the prevention of accidents.
- D. Hazard Assessment and Prevention:
 - D.1 Address all hazard assessments identified in the SAHCL, the Subcontractor's Safety Plan, and the JHA or in accordance with safety documentation requirements of the Participating Sites.
 - D.2 The Subcontractor's workers shall acknowledge being informed of the hazards and protective measures associated with assigned work activities. After the safety orientation (see paragraph 1. 5.A) submit an attendance roster with employee signatures verifying that each employee understands the safety plan and ensure that the attendance roster is always available at the jobsite.

- D.3 Instruct workers to report to the Subcontractor’s designated representative (see paragraph 1. 2.C.8) hazards not previously identified or evaluated. If immediate corrective action is not possible or the hazard falls outside of project scope, immediately notify affected workers, post appropriate warning signs, implement needed interim control measures, and notify LLNS and the Participating Site Representative, as applicable, of the action taken. Stop work in the affected area until appropriate protective measures are established.
- D.4 Establish and document procedures for routinely assessing workplace hazards produced from chemical, biological, and safety hazards at the jobsite.
- D.5 Implement a hazard prevention and abatement process to ensure that all identified and potential hazards at the jobsite are abated in a timely manner.
- E. Recordkeeping and Reporting: Report all OSHA recordable fatalities, injuries and illnesses involving the Subcontractor and lower-tier subcontractor personal and ~~any~~ property damage to LLNS and the Participating Site Representative, as applicable, immediately (within one hour of incident). Also conduct an incident investigation and submit a complete written report on DOE Form 5484.3 to LLNS and the Participating Site Representative, as applicable, within 24 hours of the incident.

The Participating Site may perform its own investigation. If an injury is involved, provide a daily verbal and written update to LLNS and the Participating Site Representative until the claimant is released to full duty and/or claim has been resolved. Work activity records shall be retained and maintained in accordance with applicable state and federal requirements.

1.3 SUBCONTRACTOR JOB HAZARD ANALYSIS (JHA) AND SAFETY PLAN

- A. Submit for Participating Site review and approval a JHA and project-specific safety plan (or equivalent documentation referred to as “ES&H Submittals” in this document) in accordance with the specified requirements. Participating Sites’ approval of the Subcontractor’s ES&H submittals shall not relieve the Subcontractor from responsibility for any errors or omissions in such submittals or from responsibility for complying with the requirements of this Subcontract (including, without limitation, these special provisions) or any applicable law or regulations.
- B. The Subcontractor shall not be entitled to a cost or a schedule adjustment due to failure to submit acceptable ES&H Submittals.

- C. When required by Task Orders issued for work at the LLNL, the Subcontractor shall generate a JHA using LLNS' on-line [LLNL TIP Tool](#). First time users will need to establish an account and complete the User Registration for access. The SAHCL number is needed for registration.

This number must also be listed as part of the Project Title for tracking purposes when generating a JHA. Instructions for completing the LLNL TIP Tool to generate a JHA are located at: <https://supplychain.llnl.gov/jha/index.html>. A copy of the completed JHA shall also be provided to the LLNS Contract Analyst. Alternatively, a paper-based JHA may be used, using the LLNS format as provided by the Contract Analyst.

- D. Immediately after the subcontract award and prior to submitting a safety plan, conduct a pre-start job walkthrough to validate the hazards identified in the specifications and the SAHCL and identify any additional hazards not listed. Prepare and submit a safety plan and a task-based JHA based upon the results of this validation. Include the work of all lower-tier subcontractors in the safety plan and JHA. Designate the individuals responsible for on-site implementation of the plan and specify qualifications for those individuals. The Participating Site will review submitted documents for acceptability and notify the Subcontractor of any deficiencies. Include in the safety plan the following:

- D.1 Job Hazard Analysis: list the work tasks to be performed, the hazards and environmental aspects associated with those tasks, and the specific controls the Subcontractor will implement.
- D.2 Implementation of OSHA requirements (e.g., hearing conservation program, respiratory protection program).
- D.3 Worker training program.
- D.4 Procedures and forms, such as confined space entry permits or aerial lift inspection forms.
- D.5 Identification of the person responsible for safety on the project.
- D.6 Injury and illness reporting program.
- D.7 Site Specific emergency response information, including a local medical provided.
- D.8 LLNS requires a comprehensive occupational medicine program for workers stationed at a jobsite for more than 30 days per year, or who are enrolled for any length of time in a medical monitoring program required by 10 CFR 851 or other federal, state or local regulation.

- D.9 Supplemental documentation as required by these specifications for specific tasks such as lift plans, complex lockout/tagout, and excavation plans.
- D.10 Records – Documentation of readiness to work, such as training records for crane operators or other designated competent personnel, medical qualifications, or certification of HEPA filter systems.
- D.11 Fulfill the management responsibilities of subpart 1. 2, above.
- D.12 Implement the worker rights and impose the worker responsibilities of these ES&H provisions.
- D.13 Define the work activities that will be performed.
- D.14 Identify and analyze hazards associated with the work.
- D.15 Develop or select applicable controls based on the hazards and requirements of this subcontract.
- D.16 Ensure the controls work properly and perform work within the controls.
- D.17 Monitor work and provide feedback on adequacy of controls and continue to improve safety management.
- E. In addition, address the following in the safety plan:
 - E.1 Project scope of work.
 - E.2 Specific construction safety measures required for the project work and specific project site and conditions.
 - E.3 Controls for common construction hazards.
 - E.4 Environmental protection.
 - E.5 Items listed in the SAHCL or equivalent Participating Site-Specific document.
 - E.6 A comprehensive occupational medicine program for workers stationed at a jobsite for more than 30 days and are enrolled for any length of time in a medical monitoring program required by 10 CFR 851 or other federal, state, or local regulation.
 - E.7 Emergency procedures for medical or fire response while on site. See 1. 7,

below.

- E.8 List the appropriate safety and health standards applicable to the work activity.
- E.9 Describe their injury/illness recording/reporting program.
- E.10 List the applicable training for workers (excluding any LLNL or Participating Site provided training identified in the subcontract).
- F. Keep one copy of Participating Site-approved, safety plan at the jobsite at all times.
- G. Submit the following task-specific safety plans if planned work includes these activities (see part 3 for details):
 - G.1 Trenching or shoring plan.
 - G.2 Fall protection plans.
 - G.3 Scaffolding plans.
 - G.4 Lifting, rigging, and hoisting equipment program
 - G.5 Task-specific rigging and lifting plan, including steel erection and equipment lifting and/or a material handling plan (refer to paragraph 3.05)
 - G.6 Confined space entry plans.
 - G.7 Personal protective equipment programs
 - G.8 Respiratory protection programs.
 - G.9 Asbestos work plans (Include evidence of exposure control effectiveness. The Participating Sites retain the right to collect samples for evaluating subcontract compliance.)
 - G.10 Lead work plans (Include evidence of exposure control effectiveness. LLNS retains the right to collect samples for evaluating contract compliance.)
 - G.11 Demolition plan
 - G.12 Silica dust mitigation plan
 - G.13 Prospective control measures to mitigate Valley Fever (Lawrence Livermore National Laboratory site, Site 300 only)

- G.14 Traffic control and safe management of circulation for vehicles, pedestrians, and bicyclists around the jobsite and staging/laydown areas.
- G.15 Complex energy isolation plan (lock-out/tag-out)
- G.16 Locating buried and hidden utilities.
- G.17 Laser use safety plan for lasers classified as 3b or greater.
- H. In addition to the other safety submittals required by this section, submit electronically the following to the Participating Site for approval within seven calendar days of Notice to Proceed:
 - H.1 The name and qualifications of the Subcontractor's safety officer (see paragraph 1.2.C.8).
 - H.2 A completed hazardous material inventory sheet. A copy of this form is included as attachment 2 to section 01 35 43 "Environmental Protection."

1.4 SUBCONTRACTOR TRAINING PROGRAM

- A. Safety Training: The Subcontractor is responsible for the safety education of its employees. Provide safety education training in accordance with all laws and standards and include additional training for site supervision. Training shall continue through the term of the subcontract. Submit copies of training certificates for each employee to the Participating Site for all operations which require such training prior to performing the work.
 - A.1 As a minimum, provide the following training for all pertinent Subcontractor personnel:
 - A.1.a Employee Orientation Training: Provide orientation training for every employee (including all sub-tier subcontractors) working on the jobsite covering the various safety policies, safety manuals, first aid availability, accident reporting procedures, safety meeting participation, personal protective equipment, enforcement procedures, and any Participating Site Specific-safety requirements that are required in the specifications or the subcontract.
 - A.1.b Supervisor Safety Training: Supervisor safety training shall cover record keeping, incident investigation, OSHA inspections, H&S documentation requirements, and the OSHA 30-hour course for construction. Submit written verification of the supervisor's safety training and certifications.

- A.1.c All employees and sub-tier subcontractors working on the jobsite shall have successfully completed the OSHA 10-hour course for construction. Submit each employee's training course certification to the Participating Site prior to the start of work.
- A.1.d Competent Person Training: Each person designated as a competent person shall attend training on that particular operation. Operations requiring a competent person in accordance with OSHA requirements include, but are not limited to, trenching, excavation and shoring, fall protection, scaffolds, confined space entry, and rigging. Provide, in writing, the names of the designated competent persons for the particular operations and the verification of their training and experience for that operation.
- A.1.e Emergency Procedures: Procedures shall cover notification procedures, evacuation routes, mustering points, and accountability. This section shall also be included as part of the employee orientation training specified in paragraph A.1.a above.
- A.1.f Lockout/Tagout: Training shall cover each individual piece of energy producing machinery or equipment that is to be removed, installed, serviced, or altered during the project. See subpart 3.9 "Lockout/Tagout LOTO" of this section.
- A.2 The following additional training shall be given to all employees performing work:
- Noise for hearing conservation
 - Ladder and stairway use
 - Proper use of personal protective equipment
 - Hazard communication
- A.3 The following additional training shall be given to employees if performing the specific work:
- Confined space entry for personnel working in confined spaces
 - Oxy-fuel gas welding and cutting safety for personnel performing oxy-fuel gas welding or cutting
 - Powered industrial truck (forklift) for personnel required to operate a forklift
 - Incidental crane safety for personnel operating hoists or cranes or rigging for a lift
 - Fall protection for personnel required to work at elevations six feet and above
 - Basic air purifying respirator training for personnel required to don respirators
 - Basic air purifying respirator training fit test for personnel required

- to don respirators
- Scissor/manlift operator training for personnel required to operate scissor lifts or manlifts
- Scaffold safety for personnel required to work from scaffolding

1.5 SUBCONTRACTOR SAFETY MEETINGS

- A. Safety Orientation: Prior to the start of work, attend a Participating Site-hosted safety orientation. The orientation will include the viewing of a general safety video, information regarding the Participating Site-specific permit process, an overview of construction safety requirements specified in this section, and a discussion of site-specific safety requirements. The orientation will take approximately one hour. Prepare an attendance roster in accordance with paragraph 1.2.D.2.
- B. Weekly Safety Meetings: Conduct weekly meetings as required by OSHA with all on-site Subcontractor and sub-tier subcontractor personnel. Prepare documentation detailing the subject discussed with signatures of all participants for each meeting and submit it to the Participating Site Representative within 24 hours after the meeting.
 - B.1 On all projects involving soil-disturbing activities at site 300 at LLNL only, communicate the risk of Valley Fever and discuss the mitigation measures to protect those potentially affected.
- C. Daily Safe Plan of Action (SPA) Meetings
 - C.1 Conduct daily SPA meetings with the work crew and each lower-tier subcontractor at the jobsite at the start of work. See Appendix A for the SPA process, a sample worksheet, and checklist.
 - C.2 The Participating Site Representative must be present at the daily SPA meetings. The Participating Site Representative must sign the SPA prior to start of the subcontract work.

1.6 EMERGENCIES

In an emergency affecting the safety of persons or property, immediately call the emergency services contact telephone numbers provided by the Participating Site (for example, call 911 from a LLNL system phone or (925) 447-6880 (LLNL Emergency Dispatch Center) from off-site, pay, or cellular phone (service is not available at Site 300), and take appropriate action to prevent or minimize damage, injury, or loss, and to preserve the integrity of the emergency site for future investigation. Promptly notify LLNS and the Participating Site Representative (as applicable) of the occurrence of such an emergency and the action taken by the Subcontractor. This notice may be verbal followed by written confirmation.

1.7 SPECIAL PROVISIONS FOR LLNL SITE 300

- A. The LLNL Site 300 location is an area where explosives are processed, transported, and tested and the area shall be treated as a hazards area. Subcontractor employees seeking access to the jobsite for the first time under this subcontract shall attend a 15-minute pre-job safety briefing at Site 300 in addition to the safety orientation (see paragraph 1. 5.A).
- B. Site 300 also has a Valley Fever Hazard. The Valley Fever Hazard and the required training to perform work at Site 300 are described in the Indemnification and Insurance Requirements, "Site 300 Valley Fever Hazard." Any soil disturbance and outdoor dust generating activities shall use effective dust control, mitigation measures, and respiratory protection for workers as necessary to limit the potential inhalation of spores.
- C. Additional work requirements are detailed in the Lawrence Livermore National Laboratory Security and Site Access Provisions.
- D. Enforcement of Regulations: Because of the nature of the operating activities at Site 300, all regulations and requirements are strictly enforced and shall be complied with at all times.

PART 2 PRODUCTS

Not used

PART 3 EXECUTION

3.1 PROTECTION OF PERSONS AND PROPERTY

- A. Erect and maintain, as required by existing conditions and performance of the subcontract, safeguards for safety and protection, including: providing lighting and ventilation; posting adequate access control signage and/or barriers with the appropriate signal words (i.e. Danger, Warning, Caution, or Notice) against hazards; issuing and posting safety regulations; and notifying the Participating Site Representative of conditions that could affect the Participating Site or other subcontractor activities at the project site, adjacent sites, or utilities sites.
- B. Notify the Participating Site Representative, when applicable) when use or storage of explosives, other hazardous materials, equipment, or unusual methods are necessary for the execution and/or performance of the subcontract work. Exercise the utmost care and carry on such activities only under the supervision of properly qualified personnel.
- C. Ventilate enclosed areas to achieve curing of materials, to dissipate humidity, and to prevent inhalation exposure and potential contamination caused by the

generation of dust, fumes, vapors, or gases.

- D. Do not perform or permit any part of the subcontract work on the project site to be performed so as to endanger the safety and/or health of persons or property. These safety management processes shall be addressed in the Subcontractor's safety plan.

3.2 PERSONAL PROTECTIVE EQUIPMENT (PPE)

- A. Personal Protective Equipment (PPE): Submit PPE Program as part of the corporate safety plan. Provide and inspect all PPE. In addition, ensure that all Subcontractor employees, lower-tiered subcontractors, and construction vendors use the appropriate PPE at all times. Construction site PPE shall minimally include:
 - A.1 ANSI Z87.1 "Occupational and Educational Personal Eye and Face Protection Devices" compliant safety glasses
 - A.2 ANSI Z89.1 "Industrial Head Protection" approved hard hats
 - A.3 ASTM F 2413 "Performance Requirements for Foot Protection" compliant safety toe work boots ("high tops")
 - A.4 Appropriate clothing (long pants and shirts with a minimum of 4-inch sleeves)
 - A.5 High visibility/reflective vests or other acceptable reflective clothing (class II), as required when work is performed in inclement weather or workers are subject to vehicle and/or heavy equipment traffic
 - A.6 Additional PPE as required by the Task Order, and as specified in the Subcontractor's safety plan.
 - A.7 Respirators selected and managed in accordance with ANSI Z88.2.

3.3 SCAFFOLDING AND LADDER SAFETY

- A. Before using scaffolding, all personnel must complete a scaffold user training course. The Subcontractor shall ensure all scaffolding is erected, maintained, and disassembled under the supervision of a competent scaffold person by properly trained workers. The Subcontractor shall conduct daily inspections by a designated competent scaffolding person and by the user before access. Comply with 29 CFR 1926 subpart L, *Scaffolds*. Train scaffolding users in accordance with 29 CFR 192.454(a). Makeshift scaffolds are not permitted.
 - A.1 Erect, maintain, disassemble, and inspect scaffolding daily under the direction of a Subcontractor-designated scaffolding competent person.
 - A.2 Submit in the JHA or corporate safety plan details of scaffolding erection,

- use, and disassembly.
- A.3 Submit training records for designated competent scaffolding persons.
- A.4 Select and use ladders in accordance with 2 CFR 1926, Subpart X, *Stairways and Ladders*.
- A.5 Inspect ladders by users prior to use.

- B. Submit a plan if using scaffolding that describes the following elements as a minimum: scaffold system; training; who are the competent personnel; tagging system; inspections; a scaffold safe use checklist for workers; and erecting and dismantling.

- C. The Subcontractor shall use personal fall protection when working from a ladder when the midsection of the worker's torso (i.e., belt buckle) is outside of the side rails of the ladder, or if it is necessary to work backwards from a ladder.

Wherever possible, work on ladders shall be performed so the worker is able to face the ladder and maintain three points of contact when climbing or descending. Materials and tools should be raised and lowered by a rope or other mechanical means. All portable ladders must be tied off or secured to prevent being displaced when the worker's feet are above 6 feet. Stepladders should be tied off whenever possible.

3.4 FALL PROTECTION

- A. Provide fall protection at the work site in accordance with 29 CFR 1926 "Safety and Health Regulations for Construction" Department of Labor or 29 CFR 1910 "Occupational Safety and Health Standards" as applicable to the work being performed. Provide all safety equipment, material, labor, and services required for compliance with this requirement. Warning line systems in compliance with OSHA 29 CFR 1926.502, (f) or OSHA 29 CFR 1910.9, (d) shall include additional warning lines or demarcation at lower levels when needed to ensure that they are visible at the employee's working level.

- B. If fall protection is applicable to the project, submit the following:
 - B.1 Fall protection program as part of the corporate safety plan
 - B.2 The assessed fall hazard at the jobsite; the selected fall protection system, personal protection equipment, and justification
 - B.3 The training for the workers and documentation of such training
 - B.4 Planned inspections of the system including worker use and equipment
 - B.5 List of qualified and competent persons and documentation of their training
 - B.6 Detailed description of the methodology for identifying anchor points, calculating clearance requirements, and rescue procedures.

Prior to starting work using fall protection equipment/system, request that the Participating Site Representative or the Participating Site ES&H team performs an

inspection of the fall protection set up and equipment.

3.5 CRANES, CRITICAL LIFTS

- A. Regulations: Conduct hoisting and rigging activities in accordance with 29 CFR 1926 Safety and Health Regulations for Construction Subpart CC, “Cranes & Derricks in Construction” and Subpart R “Steel Erection.”
- B. Applicability: Hoisting and rigging activities include use of the following equipment or devices:
 - Mobile cranes
 - Facility cranes
 - Forklifts with lifting attachments
 - Chain falls
 - Come-a-longs
 - Gantries
 - Industrial grade and/or rated: Jacks, Rollers, Dollies, Skates/skids, SPMT’s (Self Propelled Modular Transporters), Pushers/ pullers)
 - Rigging equipment, such as slings, rigging hardware, below-the-hook lifting devices, etc.
- C. LLNS Specific Requirements: LLNS exceeds OSHA requirements in the categorization and planning of lifts. LLNS requires the categorization and planning of lifts. See hoisting and rigging requirements in Appendix 01 35 23 A “Cranes, Hoists, and Rigging” following this section.
- D. Submit lift plans for Participating Site review and approval. Participating Sites will verify Subcontractor hoisting and rigging operations/equipment comply with the approved lift plan prior to lifts being performed.
- E. When synthetic slings are used and are in contact with edges, corners, or protrusions, protect slings from cutting damage with sufficient cut protection. The load rating must be determined by the cut protection product manufacturer or a qualified person.

3.6 MATERIAL HANDLING

- A. Handle materials in accordance with 1926 subpart H and/or 1910 Subpart N. Submit a material handling plan that describes the materials to be moved, when and where materials will be moved, how materials will be moved, how they will be secured if required during movement and who will move the materials.

B. Applicability

A material handling plan is required when moving items that are:

- top heavy or have an awkward weight distribution (heavy on the ends or toward the back where the material is easily tipped over or control of the material is easily lost),
- unusually shaped, configured or sized (center of gravity or balance concerns),
- in need of special handling (fragile, one of a kind, irreplaceable).
- Subcontractors can contact the Participating Site Representative for a sample material handling plan.

***NOTE:** A material handling plan is different from a lift plan. A material handling plan involves the moving of material while a lift plan involves hoisting and rigging (including raising material). If material movement involves hoisting and rigging, then submit a lift plan as well as a material handling plan as specified in section 3.5.*

3.7 AERIAL LIFTS

- A. Aerial lifts include any manual vertical aerial platforms, powered vertical aerial platforms, and boom-supported aerial platforms (e.g., extensible boom platforms, articulating boom platforms).
- B. When Subcontractor personnel operate aerial lifts, ensure lift operators are trained and qualified to operate the lift in accordance with 29 CFR 1910.66 to 68 and 29 CFR 1926.450 to 454.
- C. Aerial lifts and self-propelled elevating work platforms shall only be operated by authorized and qualified workers in accordance with the manufacturer's instructions. Workers in approved lifts shall utilize fall restraint securing to an acceptable anchor point. Operators shall perform a workplace inspection before use. If traveling 50 feet or more, the platform shall be in the lowered or stowed position. Extensible or articulating booms should be retracted or folded. The Subcontractor shall obtain the Participating Site Representative's approval if necessary to exit lifts or platforms from a height.
- D. Operators and passengers in any type of aerial lift shall use fall restraint with a body harness attached to an anchor point on the basket.
- E. The corporate safety plan shall include description of the Subcontractor's aerial lift safety and inspection program. Make operator training records and inspection records available for review at the jobsite.

3.8 ROOF ACCESS

Hazards associated with roof access may affect personnel accessing facility roofs and building occupants. Hazards include exhausted gases, fumes, or particles from rooftop stacks, chemical hoods, glove boxes, hot water boilers, and building sewer systems.

Other potential hazards include exposure to ionizing and non-ionizing radiation, electrical shock, moving machinery, explosive hazards, or contamination from previous operations or experiments. There are also fall hazards related to working at heights, slips, trips, skylights, and ladder use. Subcontractor shall comply with the Participating Site's roof access policies and procedures. For example, LLNL roofs are classified as "General Access" or "Restricted Access" depending on the hazards associated with accessing the roof. Access policies and controls vary among facilities within both classifications.

A Roof Access Permit may be required to authorize work activities for certain locations. The Participating Site Representative will obtain prior authorization and required permits to release activities to be performed on rooftops. The Subcontractor shall ensure that required procedures are followed for roof access. See the SAHCL for existing hazards.

3.9 CONFINED SPACES

A. If this subcontract requires performing work in one or more spaces that meet the Federal OSHA definition of a permit-required confined space then submit a written confined space entry program document (including a copy of confined space entry permit) along with evidence of worker training that meets the requirements of 29 CFR 1910.146, 29 CFR 1926 Subpart AA, and ANSI Z88.2. Correct noted deficiencies before performing work in the confined space. The Subcontractor's confined space entry program shall include procedures for coordinating entry operations if both Participating Site and Subcontractor personnel will enter the confined space. These joint work activities shall require the Subcontractor to perform their own atmospheric monitoring and utilize their confined space entry permit.

Participating Site personnel will conduct their own monitoring and permitting processes. In addition, execute the following:

A.1. Subcontractor shall provide for, and train their employees to use, any and all necessary equipment to perform confined space entry. This includes non-entry rescue equipment and calibrated direct-reading atmospheric monitoring equipment.

A.2. The Subcontractor shall coordinate a pre-start job walkthrough as described in paragraph 1.3B to review confined space hazards and precautions/procedures to be implemented. Submit in the JHA task specific controls such as the location of the confined space, ventilation, monitoring and any site-specific rescue procedures.

- A.3. Prior to starting work in a confined space, request that the Participating Site's ES&H group perform an inspection of the set up and equipment. Do not start work prior to a Participating Site Representative's inspection.

3.10 LOCKOUT/TAGOUT (LOTO)

- A. If working on or near equipment or systems (as defined in 29 CFR 1910.147 or 29 CFR 1910.333) with energy sources the following applies:

- A.1. The Subcontractor shall have a program described in the Subcontractor corporate safety plan for the isolation and control (lockout/tagout) of energy sources for equipment to be worked on in accordance with 29 CFR 1910.147 and the National Fire Protection Association (NFPA) 70E. LOTO of electrical circuits shall be in accordance with 29 CFR 1910.333, Subpart S, and "Electrical." The OSHA regulations permit the use of only a tag with no lock; however, this is not allowed - both a lock and tag are required. Lock and tag circuits to be worked on with keyed locks (not combination). Coordinate lockout and tagout of circuits in advance with the Participating Site Representative; do not perform lockout and tagout before obtaining the Participating Site Representative's approval. Do not allow a single individual to perform LOTO for other workers. Each affected worker shall apply their own lock and tag.

- A.2. If any of the following applies, then it is a complex/equipment specific LOTO requiring a documented written procedure:

- The equipment has potential for stored or residual energy or re-accumulation of stored energy after shut down.
- The machine or equipment has more than a single source of energy which cannot be readily identified and isolated.
- The isolation and locking out of that energy source will not completely de-energize and deactivate the machine or equipment.
- A locked-out condition cannot be achieved using a single lockout device.
- The LOTO of the equipment creates a hazard for other employees.
- The equipment has a record of energizing unexpectedly.

- A.3. If, during the course of work, a device is encountered that cannot be locked, obtain guidance from the Participating Site Representative before proceeding.

- A.4. Prior to starting work requiring executing a complex LOTO, request that the Participating Site Representative perform an inspection of the set up and equipment. Do not start work prior to a Participating Site Construction Management inspection. Submit for Participating Site approval a

documented written procedure prior to beginning work for complex LOTO work.

- A.5 The use of ‘air gap’ (or any similar term) is prohibited for LOTO-related work. Physical separation may be used within the scope of demolition or new construction activities after disconnection or prior to connection of utilities (i.e., water, gas, electrical, etc.). Physical separation may be used as an additional safety measure in conjunction with LOTO but must not be used in lieu of LOTO for service and maintenance activities.

3.11 WELDING, BURNING, OR FIRE PRODUCING ACTIVITIES

- A. Perform welding in accordance with OSHA 29 CFR 192 Subpart J and ANSI Z49.1, “Safety in Welding, Cutting, and Allied Processes,” sections 4.3 and E4.3. Do not use thoriated welding rods. Submit welding program as part of the corporate safety plan.
- B. Burn permits are required for welding, soldering, and other hot-work operations with fire potential. The Participating Site Representative will obtain permits from the Site Fire Department for the following types of activities: cutting and welding, heat treating, grinding, powder-driven fasteners, hot riveting, torching, soldering, using tar pots or tar kettles, using open fires for any purpose, barbecuing, and any other heat-producing, spark-producing tasks that could produce a fire hazard. Follow controls as prescribed on the permit and post permits in the work area until the work is completed.

3.12 LASER SAFETY

Conduct work with lasers in accordance with ANSI Z136.1, “Safe Use of Lasers.” Submit a plan specifying the controls if using lasers classified as 3b or greater.

3.13 HOT OR COLD ENVIRONMENTS

Comply with the thermal stress (cold and hot) recommendations in American Conference of Governmental Industrial Hygienists (ACGIH), “2005 TLVs and BEIs.” Submit Heat Stress Program as part of the corporate safety plan.

3.14 HEARING CONSERVATION

- A. Hearing Conservation Program: The Subcontractor shall submit a hearing conservation program to protect workers from hearing loss due to noise. The program shall consist of the following elements:
 - A.1 Submit in the corporate safety program a description of the HCP, including the following elements:

- A.1.a Annual training on noise protection (29CFR1910.95(k)(1)).
- A.1.b Description of the audiometric testing program, to include baseline and annual audiograms for exposed workers, to be provided within 6 months of the start of exposure (29CFR1910.95(g)).
- A.2 Submit in the JHA the controls specific to the work tasks to be performed which shall include the following:
 - A.2.a Baseline or periodic area noise monitoring (29CFR1910.95(d)).
 - A.2.b The type of hearing protection devices required (29CFR1910.95(i)).
 - A.2.c Identification of Exposed Personnel: Identify personnel who are exposed to noise in excess of ~~the 2005~~ the current ACGIH Threshold Limit Value (TLV) for noise. ACGIH requires HCP enrollment at 85dBA as an 8-hour TWA, with a 3dBA exchange rate.
- A.3 Worker Noise Protection:
 - A.3.a Notification and PPE: Notify workers who are exposed to noise above the TLV and provide them appropriate PPE.
 - A.3.b Engineered and Administrative Controls: Describe controls used to keep other worker's (i.e., workers not identified in paragraph A.1 above) noise exposure below 85 dBA based on an 8-hour time-weighted average.
 - A.3.c If baseline noise monitoring has been established for similar activities, then submit to the Participating Site Representative for review. Conduct noise monitoring for activities not previously base lined. All data shall be documented and kept at the jobsite location.
- A.4 At a minimum, the Subcontractor shall:
 - A.4.a Use the OSHA Required Method for Hearing Protective Device Attenuation, or
 - A.4.b Using sound level meter set to the A-weighting network, obtain representative sound level readings for the area and/or task and estimate the 8-hour Time Weighted Average (TWA). Subtract 7 dB from the NRR and subtract the result from the estimated 8-hour TWA (dBA).
- A.5 Audiometric Testing: For workers identified in paragraph A.1 above perform audiometric testing as required by 29 CFR 1910.95. The Subcontractor shall ensure that audiometric baselines are provided to employees when exposed over the ACGIH 8-hour time-weighted average of 85dba within the first 6 months of being identified to participate in the

Subcontractor's Hearing Conservation Program. Annual audiograms shall be provided thereafter.

A.6 Train workers to appropriately use established controls and PPE.

3.15 EXPOSURE PROTECTION FOR SILICA DUST

- A. Silica is a basic component of soil, sand, asphalt, stone products, joint compound, abrasive blasting media, and many other masonry building products. Silica dust is generated from work where crystalline silica-containing materials are disturbed. Protect workers in accordance with the OSHA silica standard (29CFR1926.1153) using a combination of administrative controls, engineering controls, and PPE to prevent worker exposure to respirable airborne silica from exceeding ACGIH TLV exposure limits.
- B. Baseline exposure, or objective industry data, must be used to justify the use of engineering and administrative controls and PPE to prevent exposures from exceeding the TLV.
- C. Appoint a silica competent person in accordance with OSHA silica standard (29CFR192.1153) and include in the corporate safety plan.
- D. Submit in the JHA task-specific controls.
- E. Ensure workers are not exposed to levels of silica dust exceeding 0.025 mg/m³ (the TLV established by the 2006-ACGIH) while conducting work that disturbs crystalline silica- containing materials.
- F. Use engineering controls to mitigate silica dust. Engineering controls include, but are not limited to, wet methods, local exhaust ventilation, and HEPA vacuums. Submit intended method(s) of control for review. If personal protective equipment is also required, or if respiratory protection will be used, also submit a personal protective equipment plan and respiratory protection plan. The Participating Site Representative will review these submittals for conformance with 29 CFR 1926.
- G. Submit personal air monitoring measurements collected during representative work with descriptions of the engineering controls and PPE that were utilized that demonstrates worker exposures to silica is below the 2006 version of the ACGIH TLV. Air monitoring shall be conducted in accordance with methods set forth by the National Institute for Occupational Safety and Health (NIOSH). Sample analyses shall be done by a laboratory participating in, and currently judged proficient by the American Industrial Hygiene Association (AIHA) "Proficiency in Analytical Testing" (PAT) Program. Air monitoring data will be reviewed by Participating Site Industrial Hygienists.

- H. A HEPA vacuum shall be used to clean up any silica dust and/or slurry generated during concrete or asphalt disturbance. The HEPA vacuum shall be certified in accordance with 3.17, HEPA FILTER CERTIFICATION, below.
- I. Submit a plan, if required, describing engineering, administrative, and PPE controls. Include evidence of exposure control effectiveness. The Participating Site Representative retains the right to collect samples for evaluating contract compliance.

3.16 EXPOSURE PROTECTION FOR ASBESTOS AND LEAD

See section 01 35 43, subpart 1. 8 “Asbestos” and subpart 1. 9 “Lead.”

3.17 EXPOSURE PROTECTION FOR CHEMICALS OR HAZARDOUS SUBSTANCES OTHER THAN ASBESTOS, BERYLLIUM, LEAD, OR SILICA

- A. Ensure workers are not exposed to chemicals or hazardous substances at levels exceeding the TLV established by the 2005 ACGIH. Where ACGIH has not established a TLV, use OSHA permissible exposure limits (PELs) defined in 29 CFR 1910 Subpart Z or 29 CFR 1926. Note that ACGIH TLVs are typically more stringent than OSHA PELs. In the case where the PEL is more restrictive than the TLV, workers shall be protected at the lower exposure level.
- B. Baseline Exposure Assessment Submittals:
 - B.1 Submit a description of the engineering controls (e.g., wet methods, ventilation) and personal protective equipment that will be used to mitigate worker exposures to chemicals or hazardous substances. If respiratory protection will be used, also submit a respiratory protection program. The Participating Site will review these submittals for conformance with 29 CFR 1926.
Implement OSHA requirements for substances that OSHA has established substance specific standards for (e.g., Chromium (VI), Cadmium, Inorganic Arsenic, Methylene Chloride).

When there is a reasonable expectation that an activity will exceed an applicable Occupational Exposure Limit (OEL), utilize respiratory protection unless previous exposure monitoring, objective data, or a current exposure assessment demonstrates levels below the OEL.
 - B.2 Submit personal air monitoring measurements collected during representative work and describe the engineering controls and PPE that were utilized that demonstrates worker exposures to chemicals or hazardous substances is below the relevant exposure standard. Air monitoring shall be conducted in accordance with methods set forth by the National Institute for Occupational Safety and Health (NIOSH) or OSHA

where available. Sample analyses shall be done by a laboratory participating in, and currently judged proficient by the American Industrial Hygiene Association (AIHA) "Proficiency in Analytical Testing" (PAT) Program. Air monitoring data will be reviewed by a Participating Site Industrial Hygienist.

- B.3 Submit in the JHA or corporate safety plan a description of the proposed engineering controls (e.g., wet methods, ventilation) and PPE to mitigate worker exposure to chemicals or hazardous substances.
- B.4 Provide an eyewash compliant with ANSI-Z358.1-1990 if using corrosive materials.

3.18 HEPA FILTER CERTIFICATION

Ensure the filtration efficiency of all HEPA-filtered equipment (e.g., vacuum cleaners, portable exhaust ventilation units, and negative-pressure machines) used for hazardous materials (e.g., asbestos, lead, silica, and like materials) has been certified within the past 12 months using a challenge aerosol in accordance with ASME N510 and AG1. Use HEPA- filtered equipment that has 99.7% documented filtration efficiency as a minimum. Provide documentation of HEPA filtration system certification to the Participating Site and include the name of the certifying organization, the individual that performed the test, the date that the test was conducted, the efficiency of the filter as installed in the equipment, and serial numbers for the equipment and HEPA filter. Attestation of HEPA filtration system testing meeting these criteria can either be a sticker on the equipment or a copy of documentation from the certifying organization. The Participating Site Representative may conduct performance checks of the HEPA-filtered equipment once they are at the location/building where they are intended to be used and prior to commencement of the work.

3.19 ELECTRICAL SAFETY

- A. General: Ensure that all necessary and applicable safety procedures are followed when working with electricity. In addition, submit a safety plan in accordance with subpart 1.2 "Subcontractor Safety Program" that includes a section on electrical safety. The Participating Site will review the plan in accordance with section 01 33 00 "Submittals." Demonstrate in the safety plan that all project-specific electrical safety considerations are addressed, including (but not limited to) the following:
 - A.1 Qualified electricians shall perform electrical work and in accordance with NFPA 70E and 29 CFR 1926, subparts K and V, and as provided for in the Subcontractor's safety program.

- A.2 If exposed energized parts are encountered where none were expected, particularly during testing of locked- and tagged-out circuits, stop work immediately and contact the Participating Site Representative for guidance before proceeding.
- B. Lockout/Tagout: All circuits to be worked on shall be locked and tagged in accordance with 3.9, above.
- C. Work on energized circuits is not anticipated for this project, however, contact the Participating Site Representative immediately if conditions are encountered that would necessitate working on energized circuits.
- D. In the course of this project, Subcontractor personnel may be required to work near exposed, energized equipment. Address this work in the safety plan and provide persons qualified to perform such work and all necessary safety equipment as specified in NFPA 70E and 29 CFR 1926, subparts K and V. Notify the Participating Site Representative 14 days in advance of performing the work. The Participating Site may provide guidance for performing such work.

3.20 LOCATING BURIED AND HIDDEN UTILITIES

- A. Before performing any soil, concrete, or framed wall penetrations, notify the Participating Site Representative (the Participating Site will complete utility location surveys of soil and concrete if required) and coordinate with the Participating Site Representative to secure excavation and drilling permits.
- B. Soil and Concrete Penetration Procedures:
 - B.1 General: Permits are required for any soil penetration regardless of depth. Permits may also be required for any concrete structure penetration. Notify the Participating Site Representative at least 48 hours in advance of any anticipated concrete drilling. The Participating Site Representative will determine if scanning is required, or if a permit is required.
 - B.2 Locator Services: Use the services of qualified underground utility locator service approved by the Participating Site. Alternately, the locating surveys may be performed by the Participating Site. The Participating Site Representative will furnish available documentation for the area of proposed excavation or drilling, including drawings, existing-survey data, and locating reports. Clearly delineate all areas to be excavated with white paint in accordance with California Code 4216.2 for sites located in California or state law for the applicable Participating Site. Ensure that these marks remain intact and clearly visible throughout the entire survey and excavation process.

- B.3 Excavation and Drilling Permits: No permit will be issued without a completed locating survey. Submit a permit request to the Participating Site Representative; the Participating Site will issue a permit within 7 working days of receipt of the request and the completed survey. Excavation and drilling work shall commence within 15 days of permit issuance or the permit will expire. Notify the Participating Site Representative if the period of excavation work will extend beyond 30 days from permit issuance, so that the Participating Site Representative may extend the permit. Request the Participating Site Representative to review and approve routing and penetration locations prior to continuing the work.
- B.4 Excavation: All excavation shall be carried out under the supervision of a competent person as defined by 29 CFR 1926, sections 650 and 651. If feasible, secure utilities by lock and tag procedures in accordance with this section. When excavations are planned, exercise the following cautions as a minimum:
- B.4.a When the excavation crosses or is within a 30-inch radius of a known or located utility excavate by hand or air knife until required depth is reached or utility is located.
- B.4.b When the Excavation Parallels the Located Utility: Before excavating, test the proposed route of excavation by potholing every 25 feet. Excavate potholes by hand until the required depth is reached or utility is located. If the surveyed depth of the located utility is not uniform, decrease the pothole interval distance to 10 feet. If the potholing operation locates a utility where none was expected, stop the operation and immediately notify the Participating Site Representative.
- B.4.c Place direct burial warning tape and marker along the entire length of and about 2 feet above uncovered subsurface infrastructures during backfilling. Include information on tape and coding in the survey. Place programmable electronic marker balls at the beginning and end of the newly installed utility, every 100 feet of straight runs, and at every turn or offset of the run. The Participating Site will provide programmable electronic balls and warning tape. On nonmetallic utilities install tracer wire in accordance with figure 1 at the end of this section.
- B.4.d If excavation uncovers an unidentified utility, stop excavation in this area and immediately notify the Participating Site Representative.

- C. Non-Concrete Wall, Floor, or Ceiling Penetration: Any disturbance of a non-concrete surface using, but not limited to, saw cutting, hole drilling, insertion of anchors for earthquake protection/seismic tie-downs, attaching support brackets/clips with screws or molly bolts, hanging of white boards, for utility pipes/conduits, boxes, or panels, by the means of hand tools, or by the use of power and pneumatic tools.
 - C.1 Non-Concrete Structure: A wood or metal framed structure, with an outer surface shell consisting of dry wallboard, sheetrock, plaster, stucco, sheet metal, plywood, wood, wood composite, or any other material not consisting of a solid concrete barrier. The structure may be a wall, floor, or ceiling, located in the interior, or on the exterior perimeter of a building, or trailer. The interior space between the framing members may be filled with an insulation material.
 - C.2 Required PPE: Use safety glasses with side shields and electrical-hazard rated safety shoes-boots for performing any wall penetration. In addition, use Type Class 0 electrical gloves for any penetration where electrical wiring over 50 V is suspected but cannot be located.
 - C.3 Penetrations Greater Than 1/4-Inch Into Wall Cavities or Wood and Metal Framing: Whenever a wall cavity is penetrated by more than 1/4-inch, the following shall be observed:
 - C.3.a Use Proper Analysis Tools: Use non-conductive power or manual tools, such as reamers, screwdrivers, awls, wooden-handled punches, or other blunt instrument with insulated handle. Required hand tools include small 1/8- x 8-inch long small screwdriver, hand jab- saw, battery drill, double insulated corded tools, hole saws, flashlight, fiber optic scope, and scanner. Scanners shall be standard scanners for wood and detector for metal/wire location.
 - C.3.b Plan the Penetration: Check with the Participating Site Representative for known hazards. Lay out and plan the penetration beforehand and identify all hazards on both sides of the wall. If penetration will impact fire walls, security zones, or negative air pressure controls of rooms, stop work and notify the Participating Site Representative.
 - C.3.c Identify Exterior Hazards: Surfacing material hazards such as asbestos, beryllium, lead, or other hazardous materials require additional permits, training, and PPE. If suspect hazardous materials are encountered, stop work and notify the Participating Site Representative.
 - C.3.d Identify Interior Hazards: Identify wall interior hazards such as electrical, EMT, and other ferrous or non-ferrous utilities by scanning, scoping, or cutting a view hole into the surface.

- Hand scan the area to determine location of studs, metal objects, electrical conduits, mechanical pipes, and other obstructions.
- Hand scan the area with a voltage sensitive detector for electrical circuits not in a metal conduit, such as “Romex” type wiring.
- Using non-conductive tools, poke a hole for a bore scope, or cut a view hole, at a depth equal to, but not greater than the thickness of the surface material layers. View inside structure with a flashlight, or bore scope for utilities.

C.3.e Finding and Anchoring to Framing: Verify framing and spacing to determine best placement for drill or anchoring site, particularly for weight-bearing fasteners. Determine if framing is metal or wood and check correct spacing (e.g., 16 or 24 inches). If framing can't be found by scanner, check behind walls, under floors, in false ceilings, and on other floor levels (if applicable) to determine spacing. Look inside cabinets and bookshelves for fasteners layout.

C.3.f Relocate penetrations to avoid all identified hazards.

C.3.g Drilling Procedures: Use drill bit or hole saw flagged with tape installed around it to indicate gypsum board depth. Set pilot bit as shallow as possible. Use light pressure to drill a hole to depth gauge with a battery drill. If any resistance other than the gypsum board is detected, stop work and notify the Participating Site Representative; use jab-saw to finish hole. If obstruction is present, contact the Participating Site Representative to relocate hole.

After first hole is completed, perform a visual check in wall to ensure that no obstructions are present. Follow the same procedure from the other side of the wall to complete opening.

D. As-Built: Provide utility system as-builts in accordance with the requirements for record drawings in section 01 77 00 “Project Closeout.” Show all utility elevations and all coordinate points at which utility changes of direction occur.

3.21 EXCAVATION AND TRENCHING

A. Subcontractor shall comply with California Code of Regulations (CCR) title 8, California Labor Code sections 6705 and 6707, (or all applicable Participating Site requirements, state and federal requirements and regulations for the state in which the Participating Site is located) when providing adequate sheeting, shoring, bracing, or equivalent method for the protection of life or limb.

Subcontractor's methods shall conform to and comply with applicable federal and state safety orders.

- B. Before beginning any excavation 5 feet or more in depth, submit to the Participating Site Representative a detailed plan showing the design of shoring, bracing, sloping, or other provisions to be made to protect workers from the hazard of caving ground during the excavation. The proposed plan shall comply with the standards established by State of California CCR Title 8, Construction Safety Orders and CCR Title 24, California Building Standards Code or all applicable Participating Site requirements, state and federal requirements and regulations for the state in which the Participating Site is located.

If the detailed plan varies from such shoring system standards, it shall be prepared by a registered civil or structural engineer whose name and registration number shall be indicated on the drawings.

- C. Special Trench Barricades: In areas of high population density and high pedestrian traffic, provide special open-trench barricades and protection. For open trenches adjacent to occupied buildings, crossing pedestrians, crosswalks and paths, at street intersections, and crossing or adjacent to sidewalks and driveways, the following forms of open-trench protection are required:

- C.1 Provide type II barricades, as defined in CALTRANS "Traffic Manual," (or applicable state law for sites not in the State of California) positioned on each side of the trench and at a maximum of 10-foot intervals. Spacing on each side of the trench shall alternate to show that a frontal view depicts barricades at 5-foot intervals.
- C.2 Position each barricade at least 2 feet away, whenever possible, from the open trench or excavation.
- C.3 Provide barricade with a yellow flasher at least 8 inches in diameter. (Note: Temporary barricades used during daylight operations do not require flashers.) Streetside flashers shall be directed parallel with the street; curbside flashers and flashers along pedestrian routes shall be facing in the direction of pedestrian traffic.
- C.4 When continuous solid barricades are not provided, attach interconnecting ropes or tape to all barricades. When rope is used, attach streamers at 2- to 3-foot intervals.
- C.5 Provide walkways and/or bridges with standard guard rails at all pedestrian crossing points except when trench width is 2 feet or less, a type II barricade straddling trench on either side of the walkway may be used.

- C.6 Where vehicle traffic crosses trenching operations, provide metal plate coverings to support all motor vehicles. Adequacy of the metal plate to support traffic loads is the responsibility of the Subcontractor.

3.22 DEMOLISHING UTILITIES

Paint or label existing utilities structures, subsystems, and components (SSC) to be demolished RED and notify the Participating Site Representative and request concurrence. After the Participating Site Representative concurs with the SSC selection:

- Ascertain that they are de-energized or de-energize.
- Isolate and air-gap.
- Request inspection from the Participating Site Representative for approval to demolish.
- Annotate the status as de-energized in black in the presence of the Participating Site Representative.
- Protect adjacent utilities from damage during demolition activities.

3.23 PRESSURE SAFETY

For work involving installation and or test of new building piping systems, refer to standard section 22 01 11.13 “Cleaning, Testing, and Disinfecting Building Utility Piping Systems.” This defines procedures for cleaning, testing and disinfecting, and placing into service newly installed building piping systems; use applicable Participating Site guidance as needed.

3.24 TEMPORARY TRAFFIC CONTROL

Submit a Maintenance of Traffic (MOT) plan when work may affect the safety of motorist, bicycle, or pedestrian traffic.

Provide temporary traffic control in compliance with the “California Manual on Uniform Traffic Control Devices,” a California Department of Transportation publication. Apply the applicable state requirement as needed for each Participating Site.

3.25 DIFFERING PROFESSIONAL OPINIONS

- The Subcontractor shall comply with DOE O 442.1A, *DOE Employee Concerns Program* and DOE O 442.2, *Differing Professional Opinions for Technical Issues Involving ES&H*.
- A. The Differing Professional Opinions (DPO) process encourages and facilitates dialogue and resolution on DPOs from Subcontractor employees regarding technical issues involving ES&H. It is not intended to circumvent other avenues for resolving technical disagreements but rather to supplement existing processes

for assessing and addressing technical issues related to ES&H. This process may highlight ES&H concerns, which may require LLNS to stop or curtail work operations, as necessary, to place the facility or activity in a safe condition until the DPO issue has been resolved.

- B. DOE has established a process for DPOs whereby Subcontractor employees, who believe they have knowledge of a significant technical issue related to ES&H at a DOE facility or activity that is not being properly addressed, should raise the issue in accordance with the following instructions to ensure it is properly considered in a timely manner. Subcontractor employees who submit DPOs are referred to as “submitters.”
- C. Technical issues related to ES&H may be submitted to the attention of the Department of Energy Laboratory Field Office (LFO). All submitters shall comply with the following:
 - C.1 First seek resolution through available processes (e.g., discussions with first-line supervisors or through local DPO or review and comment processes.)
 - C.2 If not resolved through available processes, submit a DPO to the applicable DPOM when it is believed the technical issue can have a significant negative impact related to ES&H. All DPOs must be in writing and should include all required information (e.g., summary of position, including proposed or established practice; recommended action; assessment of consequences and technical basis for concern; recommended technical experts; relevant documentation for review; explanation of attempts to resolve issue prior to initiating DPO, and; identification of NNSA facility and/or activity.) Additional information on the DPO process can be found at the following link:

<https://www.directives.doe.gov/directives/0442.2-BOrder/view>
 - C.3 Submit written DPOs to:

DPO Manager, NNSA/LSO Chief of Staff,
NNSA – Livermore Field Office, L-293
7000 East Avenue / P.O. Box 808
Livermore, CA 94550 / 94551
 - C.4 Meet with ad hoc panels and managers as requested and provide information as known to support a thorough review of the concern.
- D. The Subcontractor shall inform its employees regarding their right and ability to report concerns on technical issues relating to ES&H through the DPO process.

- E. The Subcontractor shall flow down the requirements of this clause to lower-tier subcontractors to the extent necessary to ensure their compliance with the requirements and the safe performance of work.

END OF SECTION
(Figure 1 follows.)

This page intentionally left blank

Figure 1. Tracer Wire Installation - Direct Burial of Nonmetallic Piping

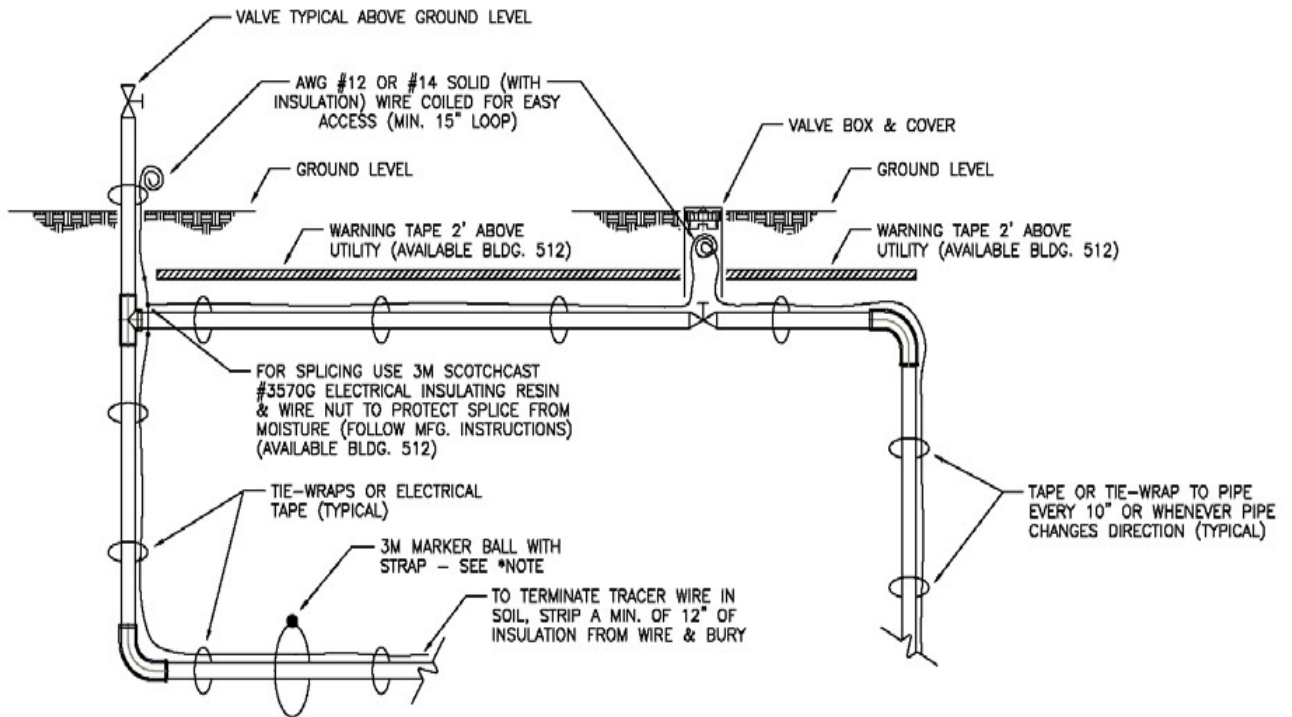

* NOTE: PROGRAMMABLE PURPLE 3M MARKER BALLS ARE AVAILABLE THROUGH THE PERMIT DESK. YOU MUST NOTIFY THE PERMIT DESK OF THE TYPE OF UTILITY, DRAWING SHOWING PLACEMENT AREA, DEPTH, PERMIT #, SIZE OF UTILITY, AND ACCOUNT # ALONG WITH WHERE THE MARKER BALL IS TO BE PLACED AND A DAMAGE PREVENTION TECHNICAL COORDINATOR WILL PROGRAM THE BALL, TAKE PICTURES OF THE AREA, AND DIRECT YOU WITH THE PLACEMENT OF THE MARKER BALLS. MARKER BALLS ARE NEVER TO BE BURIED DEEPER THAN 5' AND WILL BE INSTALLED AT THE BEGINNING, END, TEE, OR ANY CHANGE OF DIRECTION AS PER PROC-CON-0003.

LOCATING TRACER WIRE INSTALLATION FOR DIRECT BURIAL OF ALL UNDERGROUND UTILITIES
NOT TO SCALE

APPENDIX 01 35 23 A CRANES, HOISTS, AND RIGGING

PART 1 - REGULATIONS

Conduct hoisting and rigging activities in accordance with 29 CFR 1926 Safety and Health Regulations for Construction Subpart CC – Cranes & Derricks in Construction and Subpart R Steel Erection. Plan and execute lifts of personnel, such as using a hoisting device or basket, in accordance with 29 CFR 1926.1431 and ASME B30.23.

PART 2 - APPLICABILITY

Hoisting and rigging activities include use of the following equipment or devices:

- Mobile cranes
- Facility cranes
- Forklifts with lifting attachments
- Chain falls
- Come-a-longs
- Gantries
- Industrial grade and/or rated: Jacks, Rollers, Dollies, Skates/skids, SPMT's (Self Propelled Modular Transporters), Pushers/ pullers)
- Rigging equipment, such as slings, rigging hardware, below-the-hook lifting devices, etc.

PART 3 - MINIMUM REQUIREMENTS

In addition, the following minimum requirements apply to Subcontractors performing hoisting and rigging activities. Participating site requirements and local state requirements may also apply.

3.1 PERSONNEL TRAINING AND QUALIFICATION.

Provide personnel who rig loads, provide crane signal duties, and/or operate cranes or hoists that have experience and training on selection, inspection, hazards, operation, and use of hoisting and rigging equipment. Personnel must also have the following qualifications:

- Be 18 years of age or older
- Operator certification by the National Commission for Certification of Crane Operators (NCCCO) or other organization recognized by the U.S. Department of Labor
- Rigger/Signalman certification by the National Commission for Certification of Crane Operators (NCCCO) or other organization recognized by the U.S. Department of Labor.

3.2 EQUIPMENT INSPECTION AND MAINTENANCE.

Tag rigging equipment with capacity. Provide documentation upon request demonstrating that the equipment passed an annual inspection within 1 year from date of intended use, and passed a preoperational inspection prior to use.

Store rigging equipment properly (e.g., on racks or in protected areas). Inspect rigging equipment in compliance with 29 CFR 1926.1400. Maintain inspection records at the project site.

3.3 LIFT CLASSIFICATION

Classify lifts during the bid walk into one of the following categories: simple, complex or critical. Provide input during the bid walk to the Participating Site as appropriate to determine the lift categories.

A. **Simple lift**

Lifts that are not categorized as complex, critical or personnel are simple lifts

B. **Special-Ordinary**

Lifts where any of the following conditions are present:

- B.1 The load will be rotated or manipulated on or about its x or z axis.
- B.2 The load will be transferred (i.e., in mid-air from one crane to another).
- B.3 Any load where the center of gravity might move during the lift, such as a tank filled with liquid.
- B.4 Use of multiple lifting devices; such as use of more than one lifting equipment (i.e., cranes, hoists, forklifts, jacks) in sharing the load.
- B.5 LLNS or the Participating Site may choose to classify a lift as Special-Ordinary.

C. **Critical lift**

Lifts where any of the following conditions are met:

- C.1 Loss of control of the load being lifted would likely result in the declaration of an emergency.
- C.2 The load is unique and vital to a system, facility, or project operation, and would be irreplaceable or not repairable if damaged.
- C.3 If the load is damaged, the cost to replace or repair the load, or the delay in operations would have a negative impact on facility, organizational, or

DOE budgets that would affect program commitments.

- C.4 If mishandling or dropping of the load would cause any of the above consequences to nearby installations and facilities.
- C.5 For steel erection, the lift exceeds 75 percent of the rated capacity of the crane or derrick or requires the use of more than one mobile crane or derrick (refer to 29 CFR 1926.751).

3.4 LIFT PLAN REQUIREMENTS

Submit lift plans for lifts (except simple lifts that are less than 2000-lbs). The Subcontractor may include multiple lifts at a construction location in a single lift plan.

- A. Address the following in the lift plans:
 - A.1 Designate personnel roles, as shown in the table below.
 - A.2 Break the lifting activities down to the task level (staging, rigging, pre-lift, lift, and securement), using drawings and/or text.
 - A.3 Characterize the load: weight, dimensions, center of gravity, rigidity, stability, and rigging attachment points. Verify undocumented attachment points by calculation to demonstrate adequacy.
 - A.4 Define the work area:
 - Boundaries and access control
 - Travel path of the load
 - Start, staging, and finish points
 - Equipment, facilities, or structures that pose obstructions or impediments to moving/manipulating the load
 - Imposed loads on structures, utilities (above/below grade)
 - Weather considerations

- Identify the lifting and rigging equipment: type (use the categories in section B), capacities (load charts), physical size (length, width, height, physical compatibility), and rigging equipment (slings, rigging hardware, below-the-hook lifting devices).
- Describe securement of the load.
- Provide load path calculations (identify the forces that are effecting the rigging equipment).
- Provide mathematical calculations to demonstrate the load/object moves only due to forces and moments appropriately applied to start and stop desired motion.
- Demonstrate that equipment and components are within design constraints, and peripheral issues (ground bearing issues, crane mat calculations, and prohibited zones for power lines) are properly addressed.

B. Requirements and documentation for the different categories of lifts are shown in the table below:

Requirement:	Lift Type:			
	Simple <2000 lbs	Simple >2000 lbs	Complex	Critical
Documented Lift Plan	Not required.	Required.	Required.	Required.
Designation of Personnel Roles	Appoint a Designated Leader (DL); Participating Site concurrence. Designate in lift plan, present at work site for entire lifting operation, may delegate or transfer. Communicate DL changes verbally.	Appoint a Designated Leader (DL); Participating Site concurrence. Designate in lift plan, present at work site for entire lifting operation, may delegate or transfer. Communicate DL changes verbally.	Appoint a Designated Leader (DL); Participating Site concurrence. Designate in lift plan, present at work site for entire lifting operation, may delegate or transfer. Communicate DL changes verbally.	Appoint a Person In Charge (PIC); Participating Site concurrence. Designate in lift plan, present at work site for entire lifting operation, and cannot be delegated or transferred.

Inspections	Hoisting and rigging equipment shall meet ASME B30 requirements. Provide current certifications and inspection records. Participating Site shall inspect and approve equipment upon arrival at Site. Request that the Participating Site Representative inspect set up and equipment prior to each lift.	Hoisting and rigging equipment shall meet ASME B30 requirements. Provide current certifications and inspection records. Participating Site shall inspect and approve equipment upon arrival at Site. Request that the Participating Site Representative inspect set up and equipment prior to each lift.	Hoisting and rigging equipment shall meet ASME B30 requirements. Provide current certifications and inspection records. Participating Site shall inspect and approve equipment upon arrival at Site. Request that the Participating Site Representative inspect set up and equipment prior to each lift.	Proof load test rigging equipment (slings, below-the-hook lifting devices, and rigging hardware) in accordance with applicable ASME standard. Participating Site shall inspect and approve equipment upon arrival at Site. Request that the Participating Site Representative inspect set up and equipment prior to each lift.
Drawings			Scaled drawings required	Scaled drawings required
Pre-Lift Meeting			Required.	Required. Must be documented in lift plan.
Practice Lift				Required as specified by Participating Sites.
Post-Lift De-Brief		Required	Required.	Required.

PART 4 - REQUIRED SUBMITTALS

Submit the following information/documents to LLNS and the Participating Site (joint submittal):

- A. Completed Lift Plan (may utilize template provided by LLNS)
 - C.1 Submit the lift plan(s) to LLNS and the Participating Site for review and approval at least 30 business days prior to the commencement of the specific lift.
 - C.2 Include scaled drawings for Special-Ordinary and Critical lifts
- B. Note: Present deviations from an approved lift plan to the Participating Site Representative for approval prior to proceeding.
- C. Certification/Qualification documents for Crane Operators, Riggers and Signal Persons

- C.1 Provide personnel qualifications fifteen work days prior to the beginning of the work activity or upon arrival of the personnel at the Site for approval by the Participating Site Representative.
- C.2 Age verification (i.e., employees are over 18 years of age) for employees involved with cranes, hoisting and rigging
- D. Current crane certifications and inspection information
- E. ASME certifications and inspection records for the equipment used for hoisting and rigging
- F. ASME proof load test documentation for slings, below-the-hook lifting devices and rigging hardware used for critical lifts

This page intentionally left blank

SECTION 01 35 23 19 — ASBESTOS SAFETY — CLASS III

PART 1 GENERAL

1.1 SECTION INCLUDES

- A. This section defines requirements for performing class III asbestos work in accordance with CCR title 8, section 1529 for Participating Sites located in the state of California.
- B. Asbestos is only known to be present in the materials indicated in the Task Order.
- C. All work performed at sites located in states other than the state of California shall be conducted in accordance with the applicable state laws, regulations, and requirements and the applicable Participating Site-Specific Requirements as noted in the Construction Management Task Order.

1.2 REFERENCES

- A. The following documents form a part of these specifications to the extent stated herein.
- B. Code of Federal Regulations (CFR)
 - 29 CFR 1910 Occupational Safety and Health Standards (Fed/OSHA)
 - 29 CFR 1926 Safety and Health Regulations for the Construction Industry, Department of Labor (DOL)
 - 40 CFR 61 National Emission Standards for Hazardous Air Pollutants (NESHAPS)
 - 40 CFR 763 Asbestos Hazard Emergency Response Act (AHERA)
- C. California Code of Regulations (CCR), for Participating Sites located in California
 - CCR Title 8 Industrial Relations (Cal/OSHA Regulations) Section 1529 Asbestos
 - CCR Title 22 Div 4.5 Environmental Health Standards for the Management of Hazardous Waste
 - CCR Title 26 Toxics
- D. Bay Area Air Quality Management District (BAAQMD) Rules and Regulations Regulation 11, for Participating Sites located in California
 - Hazardous Pollutants:
 - Rule 2. Asbestos Demolition, Renovation and Manufacturing

- E. San Joaquin Valley Air Pollution Control District (SJVAPCD) for Participating Sites located in California
SJVAPCD National Emission Standards for Hazardous Air Pollutants Regulation IV (Adopts NESHAP Standards) Rule 4002
- F. National Institute of Occupational Safety and Health (NIOSH)
NIOSH Manual of Sampling Data Sheets, Method 7400
NIOSH Transmission Electron Microscopy (TEM)
OSHA Equivalency Method, Method 7402
- G. National Fire Protection Association (NFPA), NFPA 701, *Standard Methods of Fire Tests for Flame Propagation of Textiles and Films*

1.3 SUBMITTALS

- A. **Asbestos Abatement Work Plan:** Submit an “Asbestos Abatement Plan” to the Participating Representative Site for approval prior to the start of any handling of asbestos at the site. This plan shall detail the manner in which the Subcontractor shall conduct the specified work and the procedures and equipment to be used to ensure that Participating Site Representative and Subcontractor employees are not unnecessarily exposed to asbestos, Participating Site facilities are not contaminated, and the environment is protected. This document shall present the engineering, administrative, and personnel-protective controls that ensure compliance with the applicable provisions of these specifications and all applicable regulations and laws. It shall describe the manner in which asbestos-containing waste shall be contained, stored, transported, and disposed. The use of power tools, unless exhausted through a HEPA filter, is prohibited. Address the following in the asbestos abatement work plan:
 - A.1 **Isolation Controls:** Describe the equipment, supplies, and techniques used to isolate a regulates containment area. Describe the engineering controls employed.
 - A.2 **Air Sampling Plan:** Include the personal air-sampling plan described in these specifications.
 - A.3 **Negative-Pressure System:** Describe the selection, testing, staging, use, and monitoring methods for equipment to provide a negative pressure in the asbestos-removal area.
Provide a diagram of abatement area including negative pressure machine(s) and decontamination chambers.
 - A.4 **Waste Handling:**
Non friable ACM: Describe the containment, storage, transportation, and disposal methods for nonfriable asbestos-containing waste and asbestos

items.

Friable ACM: Describe the containment and turn-over methods for friable ACM turned over to the Participating Site for disposal.

- B. **Prestart Submittals:** Provide the following items to the Participating Site prior to the start of asbestos-handling work:
- B.1 Proof of current registration with the California Department of Industrial Relations, or the applicable State agency for the Participating Site, as a handler of carcinogens
 - B.2 Proof of notification of California Department of Industrial Relations, or the applicable State agency for the Participating Site
 - B.3 Where applicable, a copy of required demolition notification to local air district
 - B.4 Evidence of employee training meeting the 40 CFR 763 (AHERA), 29 CFR 1910 (Fed/OSHA), and CCR title 8 (CAL/OSHA) requirements for all employees performing the work of this section
 - B.5 Evidence of training and fit testing and training of each employee for the use of any respirator to be used performed by a qualified individual within the past 12 months, including positive pressure respirators, on this project with the employee's name with each record
 - B.6 Evidence of supervisor training meeting the AHERA, Fed/OSHA, and CAL/OSHA (or the applicable state agency for the Participating Site) requirements for all supervisors
 - B.7 Evidence of medical surveillance for all employees using respirator or otherwise, where medical surveillance is required by Federal and CAL/OSHA (or the applicable state agency for the Participating Site) regulation
 - B.8 Subcontractor's respiratory protection policy
 - B.9 Evidence of air monitoring data if the Subcontractor uses a Negative Exposure Assessment (NEA).
 - B.10 Subcontractor's respiratory protection policy.
 - B.11 Evidence of HEPA-filtered equipment certification (see Section 01 35 23 "General Safety Provisions," Subpart 3.18, "HEPA Filter Certification").
 - B.12 Asbestos-abatement work procedure and safety plan, as required herein.

- B.13 Evidence of a valid BAAQMD (or applicable agency relative to the Participating Site) Acknowledgement of Demolition/Notification and Payment Fees or SJVAPCD (or applicable agency relative to the Participating Site) Demolition/Renovation Permit Release for the specific project:
 - a. For Livermore Site: Friable ACM removal greater than 100 linear feet, 100 square feet, or 35 cubic feet, submit a separate BAAQMD asbestos notification specific for the project. If a structural element is involved submit a demolition Notification.
 - b. For Site 300: Friable ACM removal greater than 160 linear feet, 260 square feet, or 35 cubic feet, submit a SJVAPCD asbestos notification for the project. If a structural element is involved, submit a Demolition Notification.
- B.14 Name and address of site where nonfriable asbestos waste will be disposed (See Section 3.07).
- B.15 Copy of asbestos-related insurance coverage.
- B.16 Descriptive literature on specified equipment and material, as listed below:
 - a. Negative pressure machines
 - b. Water-filtration system and filters
 - c. Wetting materials, encapsulants, spray glues, and other chemicals
 - d. Fire-resistant plastic or other materials used in construction of isolated area
 - e. Respirators
 - f. Negative-pressure monitor
 - g. Air-sampling pump
 - h. Fire extinguishers brought on-site
 - i. Ground fault circuit interrupters (GFCI)
 - j. Floor buffer machines and associated pads
 - k. Alternative removal devices, such as water jet sprayers and infrared heating machines
 - l. Temporary water-resistant lighting
- C. **Daily Submittals:** Submit the following items to the Participating Site Representative within one working day following the day on which the results are available.
 - C.1 Submit results of personal air monitoring (8-hour time-weighted average and excursion results, as well as raw laboratory data) to the Participating Site within one working day following the day on which the results are available.
 - C.2 Copies of print-out from negative pressure monitors.
- D. **Final Submittals:** Following the completion of asbestos-handling work, submit copies of access logs for the regulated area and completed shipping documents.

1.4 TRAINING AND QUALITY ASSURANCE

- A. **Employee Training Qualifications** The following is mandatory Subcontractor-provided training for Subcontractor employees performing asbestos-handling work:

- A.1 All Employees:** Trained and certified in accordance with the federal or State of California (or State for the Participating Site) OSHA requirements, and meet the training provisions for “workers” of AHERA as codified in 40 CFR 763. Employees must have current certification with documented attendance at applicable certification refresher classes.
- A.2 Supervisor/Competent Person:** Each individual assigned to work as a supervisor shall meet the requirements for a “competent person” as described in 29 CFR 1926.1101 and, for a “supervisor” as required by AHERA, as codified in 40 CFR 763. The supervisor/competent person must have current certification with documented attendance at applicable certification refresher classes.

PART 2 PRODUCTS

2.01 GENERAL

Provide all material, equipment, tools, and devices required to complete the asbestos work safely in accordance with 29 CFR 192.1101.

- A. Polyethylene sheeting shall be fire retardant with a minimum thickness of 6-mil where the largest size possible is provided to minimize seams.
- B. Asbestos waste bags and glove bags shall be 6-mil thick.

PART 3 EXECUTION

3.1 PROTECTION

- A. **Personal-Protective Equipment (PPE):** Use personal-protective equipment (PPE) to minimize Subcontractor employee exposure to asbestos as described in CCR title 8, section 1529 (or the applicable state agency for the Participating Site) and 29 CFR 1926.1101 and below:
- A.1 **Use respirator protection in accordance with 29 CFR 1926.1101.**
 - A.2 **Protective Clothing:**
 - Wear disposable-type full-body protective clothing, including foot, hand, and head covering, as required by Fed/OSHA when working in a regulated, containment area.
 - Make disposable protective coveralls, shoe covers, and gloves available for use to qualified Site inspectors. Stage this gear at the entrance to each isolated area or at the perimeter of each asbestos-work area. Provide at least four sets of disposable gear each day for each work area after starting the asbestos-removal work and until the area successfully passes the final clearance sampling.
 - A.3 **Other Protective Gear:** Provide other necessary protective gear, including boots, goggles, and hardhats, and enforce the use of the provided gear.

3.2 ENGINEERING CONTROLS AND GENERAL WORK PROCEDURES

- A. Perform asbestos work in accordance with controls outlined in 29 CFR 1926.1101 for class III or IV work.
- B. Unless specifically exempted by the Construction Management Task Order, all ACM shall be handled in a wet state.
- C. Water with an appropriate wetting agent or use a removal encapsulant to wet all materials prior to and during handling. The wetting agent shall be approved the Participating Site Representative and the Participating Site ES&H group prior to the start of work.
- D. Post DANGER Asbestos Work Area signs at entrances to regulated work area in accordance with 29 CFR 1926.1101.
- E. HEPA-Filtered Equipment Testing: Test and certify HEPA-filtered equipment in accordance with General Safety Provisions Section 01 35 23, Subpart 3.18.
- F. When using HEPA-filtered vacuum cleaner to provide negative pressure to mini-enclosure or glove bag, the vacuum cleaner must pass the current certification test with the past 12 months and is only used as part of the work of this section.
- G. For “unclassified” asbestos work, work in accordance with controls outlined in 29 CFR 1926.1101, Subpart G.

3.3 CLASS III PROCEDURES AND CONTROLS

- A. The Subcontractor is permitted to use class III procedures and controls. Conduct the work using, at a minimum, the following procedures:
 - A.1 Evacuation Area: Where class III work procedures are used, all persons not directly involved in the asbestos work or lacking the required personnel protective gear, shall be evacuated from the area in which the work is being performed. All nonprotected personnel shall be removed from a radius of 25 feet from the work area. This 25-foot radius shall constitute the perimeter of a restricted access zone and shall be marked by erection of a barrier such as stanchions and warning tape, or approved equivalent.
 - A.2 Signage: Post the perimeter of the restricted access area around the work zone with the OSHA required warning sign, approved as to form and size by the Participating Site Representative.

3.4 FRIABLE ACM

- A. In addition to other controls of this part, the following steps shall be taken for any work that may involve disturbing friable ACM:
 - A.1 After obtaining approval from the Participating Site Representative, shut off or temporarily modify the air-handling system, and restrict other sources of air movement. Notify the Participating Site Representative at least 14 days prior to any required shutdown so that the Participating Site can ensure existing facility operations are not jeopardized by a shutdown.
 - A.2 Use negative-pressure enclosure and glove-bag operations to prevent the spread of any fibers released by the work being performed.

3.5 GLOVE BAG OPERATIONS

- A. Perform asbestos work in accordance with controls outlined in 26 CFR 1926.1101 for class III work.
- B. Use personal protective clothing, such as the “Tyvek” suits, gloves, and a respirator that has been fitted in accordance with OSHA.
- C. Isolate the area where the ACM is located. Place barrier tape across the doorways and at least 20 feet around the area where the ACM is located.

Place 6-mil plastic sheeting under the glove bag set-up.
- D. Ensure that all ventilation units that service the area where the ACM is located are shut off and tagged out.
- E. Don the respirator and perform a “negative” and “positive” pressure test. Do not proceed with ACM work without a proper respirator fit.
- F. Determine the area where the ACM is to be removed. Place the glove bag next to the pipe and measure how much area will need to be removed. Tape the area on the pipe to delineate the area from which ACM will be removed. Tape the bottom seam of the glove bag. Slit the side seams of the glove bag to fit the pipe diameter. Seal the sides and top seam with tape after placing the necessary tools into the bag. Cut a small hole in the bag in the same area where the wetting wand will be placed during the actual ACM removal stage. Fill the bag with smoke from the smoke tube and seal the hole. Gently squeeze the bag and observe any leaking areas. Tape the leaking areas to achieve an airtight seal. If the pipe lagging is badly damaged or deteriorated the ACM may require wetting or taping to prevent a further release of fibers.
- G. Wet the ACM completely prior to removal and keep the ACM wet during the removal process. Use amended water in an airless spray pump. A hand spray bottle may also be used. The hole created for the spray wand can also be used for

the HEPA vacuum nozzle.

- H. All visible ACM shall be removed from the pipe using a hard brush and amended water while the glove bag is still in place. Wet wipe and spray the pipe with encapsulant prior to removing the glove bag. Special attention shall be given to exposed ends of pipe lagging.
- I. Place all tools into one of the armholes and pull inside out. Tape and cut the arm from the glove bag and remove the tools while they are still sealed in the arm or glove.
- J. Wet the inside of the bag with amended water and place the vacuum nozzle into the bag to cause the bag to collapse. Unseal the bag and remove from the pipe. Handle waste in accordance with requirements for waste handling subpart 3.11.
- K. The exposed section of pipe shall now be closed and sealed with a non- asbestos material.
- L. If the remaining pipe contains ACM, the pipe shall be labeled "DANGER ASBESTOS MATERIAL."

3.6 ASBESTOS REMOVAL USING MINI-ENCLOSURES

- A. Except in circumstances where the Participating Site permits other procedures, handle asbestos within a mini-enclosure, as defined in 29 CFR 1926.1101. A mini-enclosure is a small walk-in enclosure that cannot accommodate more than two people. Characteristics of a mini-enclosure include isolation of the work area from surrounding areas (typically using disposable plastic sheeting) and establishment of negative pressure within the isolated area. Where the mini-enclosure area approach is used, the minimum characteristics of that work must include the following items, in addition to other applicable requirements presented in this section and in applicable regulations and laws.

A.1 Isolation

- Shutoff and tagout all ventilation units that service the area where the asbestos-containing material from surrounding areas of the building or the general environment by constructing a mini-enclosure. Construct this enclosure from materials that meet the fire-resistance requirements.
- "Critical barriers" are initial covers installed over ventilation duct openings, windows, doors, and other transitions from the work area to adjacent non-isolated areas, including doorways on the decontamination chambers.
- Provide transparent viewing ports at appropriate locations in critical barriers to all Participating Site Representatives or local air quality district (BAAQMD, SJVAPCD, or applicable district for the Participating Site) representatives to observe the work areas from

outside the barriers.

- Make barriers isolating the work area from the surrounding areas complete and as airtight as possible.
- Design the above listed isolation controls such that they remain intact and airtight throughout the expected duration of the work in the isolated area.

A.2 Inspect the mini-enclosure for leaks and smoke-tested to detect breaches.

- Seal all breaches prior to start.

A.3 Air movement within the mini-enclosure will need to be directed away from the employee's breathing zone.

3.7 ADMINISTRATIVE CONTROLS

A. Personal Hygienic Practices and Housekeeping

A.1 Do not eat, drink, use tobacco products, or apply cosmetics in the designated regulated area.

3.8 AIR-SAMPLING PLAN

A. Conduct employee sampling in accordance with Fed/OSHA requirements pertaining to air-sampling.

B. Submit to the Participating Site, prior to the start of asbestos-handling work, a personal air-sampling plan for implementation during the asbestos-handling work, designed to conform to and comply with Fed/OSHA requirements. Include the following minimum elements in the plan:

B.1 Where using respirators other than type "C" air-supplying, provide representative employee monitoring in a manner adequate to calculate an 8-hour time-weighted average and an excursion exposure on each shift during which workers handled asbestos materials. Where using type "C" respirators, provide initial representative samples and subsequent weekly samples.

B.2 A laboratory certified by the American Industrial Hygiene Association (AIHA) in the analysis of air samples by NIOS 7400 or Fed/OSHA reference method must perform the sample analysis in accordance with these methods. In addition, the analyzing laboratory must meet the other

requirements for analyst training and quality control as described in 29 CFR 1926.1101.

3.9 RESPONSE TO FAILURE OF CONTROL PROCEDURES

Elevated Perimeter Sample

- A. If a perimeter sample initially obtained by the Participating Site and analyzed by phase contrast microscopy (PCM) (see Subpart 3.12 “Inspections and Air Sampling Conducted by Participating Site”) is found to exceed 0.01 fibers per cubic centimeter (f/cc) or the per-established baseline level, immediately stop asbestos-removal work. If the Subcontractor obtained the sample, immediately inform the Participating Site of the elevated sample result.
- B. The Participating Site may convene a meeting within 24 hours to determine the cause of the elevated fiber levels. If the Participating Site determines that the elevated fiber level most likely resulted from failure in the Subcontractor’s control procedures, the Participating Site may have the subject samples re-analyzed by TEM to verify that the fibers detected are asbestos.
- C. If analysis indicates the presence of asbestos in concentrations greater than 0.01 f/cc (or 70 s/mm²), do the following:
 - C.1 Make corrections or improvements to work procedures to reduce leakage of fibers from work area.
 - C.2 Erect critical barriers surrounding area where elevated asbestos level was detected.
 - C.3 Decontaminate surrounding areas, as stipulated by Participating Site.
 - C.4 Continue decontamination until samples by the Participating Site, taken using appropriate procedures and analyzed by TEM or PCM, indicate an airborne asbestos level of less than 70 s/mm² or 0.01 f/cc.
- D. **Observed Deficiency in Engineering Controls**
Immediately correct observed deficiencies in engineering controls, such as failure of plastic barriers or covering, loss of required negative pressure, clogging of shower drains, and loss of exhaust airflow. If the problem cannot be corrected immediately, stop asbestos work pending correction of the deficiency.
- E. **Observed Deficiency in Work Practices**
Promptly correct identified deficiencies in work practices, use of equipment, and personal-protective controls.

3.10 NONFRIABLE ACM

- A. Non-friable asbestos that may be encountered is specified in the Task Order.
- B. Remove all non-friable ACM under wet conditions.
- C. Perform all vacuuming with a HEPA-filtered vacuum only.
- D. Mopping or wet wiping may be used to wet-clean debris (which shall be assumed to contain asbestos) from the floor. The mop or wipe is to be moved in one direction for no more than six feet, turned over, and then the action must be repeated for six more feet in the same direction. At the end of the two passes the mop or wipe is to be rinsed in a water bucket. These actions may be repeated, utilizing the same bucket of water until the water becomes visible soiled.
- E. Mop heads and wipes shall be used for one project only. They shall be disposed of by placing them into an asbestos disposal bag at the end of the project. Asbestos-containing rinse water may also require controlled disposal. Contact the Participating Site Representative for guidance on disposal of all asbestos-contaminated wastes.

3.11 WASTE HANDLING

- A. Dispose of all asbestos-containing waste and all items which have been contaminated with asbestos, other than those items which are to be decontaminated or managed by the Participating Site.
- B. Ensure that all asbestos containing waste is handled, contained, labeled, stored, transported, and disposed of in accordance with applicable laws, codes, and regulations. Mark all vehicles used to transport asbestos-containing waste material as specified below during loading and unloading of waste.

DANGER ASBESTOS DUST HAZARD
CANCER AND LUNG DISEASE HAZARD AUTHORIZED PERSONNEL
ONLY

- C. Seal waste in airtight containers. Seal the waste in one 6-millimeter gauge or thicker plastic bag and subsequently seal in a second similar bag or metal or plastic drum. Place liquids contaminated with asbestos (e.g., unfiltered shower water) in metal or plastic drums. Ensure proper labeling of secondary bags or drums.
- D. The Participating Site Representative will coordinate the management and disposal of all hazardous waste.

3.12 INSPECTIONS AND AIR SAMPLING CONDUCTED BY THE PARTICIPATING SITE

- A. The Participating Site Representative will conduct and oversee a variety of inspections of the work site to ensure compliance with the provisions of this section and applicable laws and regulations. These inspections may include, but not be limited to, the following:
 - A.1 Inspection of engineering controls used by the Subcontractor
 - A.2 Inspection of PPE used by the Subcontractor, including the use of respirators and protective clothing
 - A.3 Inspection of the work practices used by the Subcontractor, including asbestos wetting and removal procedures, and decontamination procedures
 - A.4 Perimeter sampling may be conducted to verify the adequacy of the Subcontractor's isolation or class III work procedures. These samples will be taken outside of restricted perimeters established for class III work. Perimeter samples shall be analyzed in accordance with NIOSH 7400. Air samples shall not exceed 0.01 fibers per cubic centimeter (f/cc) of air, or a baseline fiber level established by the Participating Site ES&H group, whichever is higher. This is referred to as the "perimeter limit."
 - A.5 A preclearance visual inspection shall be conducted in the work area after all asbestos has been removed. To successfully pass this inspection, there shall be no visible residue of the removed material. Schedule this inspection with the Participating Site Representative at least 24 hours in advance.
 - A.6 A final clearance sampling may be conducted to verify acceptable air quality within the control area prior to re-occupancy. These samples will be taken inside of restricted perimeters established for class III work. Clearance samples will be analyzed in accordance with NIOSH 7402. All air samples shall not exceed 0.01 f/cc of air.

END OF SECTION

This page intentionally left blank

SECTION 01 35 23 21 — LEAD WORK EXPOSURE PROTECTION

PART 1 GENERAL

1.1 SUMMARY

Lead may be encountered as part of this work. This section defines requirements for protection from exposure to lead for personnel in or near the lead work area and for prevention of cross contamination of lead dust to facilities and equipment. All lead work shall be conducted in accordance with 29 CFR 1926.62. The Subcontractor shall ensure that no employee is exposed to lead at concentrations greater than the permissible exposure limits (PELs) defined by OSHA.

1.2 REFERENCES

- A. The following documents form a part of these specifications to the extent stated herein.
- B. Code of Federal Regulations (CFR)
 - 29 CFR 1910 Occupational Safety and Health Standards (Fed/OSHA) OSHA Method ID121: Metal & Metalloid Particulates in Workplace Atmospheres (Atomic Absorption)
 - 29 CFR 1926.59 Hazard Communication Safety and Health Regulation for the Construction Industry
 - 29 CFR 1926.62 Lead Safety and Health Regulation for the Construction Industry
- C. Department of Energy (DOE)
 - DOE-STD-3020 Specification for HEPA Filters Used by DOE Contractors (2005)
- D. Consumer Product Safety Commission (CPSC) CPSC
 - Established limits for lead in paint
- E. National Institute of Occupational Safety and Health (NIOSH)
 - NIOSH 7082 Lead by Flame AAS (Atomic Absorption Spectrophotometer)
 - NIOSH 7105 Lead by HGAAS (Atomic Absorption Spectrophotometer, Graphic Furnace)

1.3 DEFINITIONS

- A. AIHA = American Industrial Hygiene Association
- B. AL = Action Level of thirty micrograms per cubic meter of air (30 $\mu\text{g}/\text{m}^3$) averaged over an 8-hour period
- C. CDC = Center for Disease Control
- D. CFR = Code of Federal Regulations
- E. CPSC = Consumer Product Safety Commission
- F. ELLAP = Environmental Lead Laboratory Accreditation Program
- G. EPA = Environmental Protection Agency
- H. HEPA = High-Efficiency Particulate Air
- I. MSDS = Material Safety Data Sheet
- J. NID = Negative Initial Determination. An exposure assessment also considers other information, including levels of worker training, supervision and previous monitoring results. A conclusion that the planned work (including trigger tasks) will not exceed the PELs and will be conducted under situations closely resembling other similar jobs is called an NID (or negative exposure assessment).
- K. NIOSH = National Institute of Occupational Safety and Health
- L. OSHA = Occupational Safety and Health Administration
- M. PAO = polyalpha olefin
- N. PEL = Permissible Exposure Limit of fifty micrograms per cubic meter of air (50 $\mu\text{g}/\text{m}^3$) averaged over an 8-hour period
- O. PPE = Personal Protective Equipment
- P. TCLP = Toxicity Characteristics Leaching Procedure

Q. Trigger Tasks:

Q.1 Group 1: Tasks/operations with presumed employee exposures above the PEL but below 500 ug/m³. The Subcontractor shall provide a respirator with an assigned protection factor of at least 10. Examples are:

- manual dry scraping and sanding
- manual demolition of structures
- heat gun applications
- power tool cleaning with dust collection systems
- spray painting with lead-based paint

Q.2 Group 2: Tasks/operations with presumed employee exposure above 500 ug/m³ but below 2,500 ug/m³. The Subcontractor shall provide the employee with a respirator with an assigned protection factor of at least 25. Examples are:

- lead burning
- using lead-containing mortar
- power tool cleaning without dust collection systems
- rivet busting
- cleaning activities where dry expendable abrasives are used
- movement and removal of abrasive blasting enclosures

Q.3 Group 3: Tasks/operations with presumed employee exposure above 2,500 ug/m³. The Subcontractor shall provide the employee with a respirator permitted by the standard for use during that exposure condition (e.g., a respirator with an assigned protection factor above 50). Examples are:

- abrasive blasting
- welding, cutting, and torch burning on steel structures

1.4 EXPOSURE ASSESSMENT

A. The exposure assessment shall initially determine, by a review of previous exposure monitoring data, objective data, calculation, or air sampling plan, if any employee may be exposed to lead at or above the OSHA action level or at or above the level indicated for the appropriate trigger task in compliance with 29 CFR 1926.62 (d).

Conduct all air sampling in accordance with 29 CFR 1926.62 to initially determine if any employee may be exposed to lead at or above the OSHA action level and/or at or above the exposure controlled by the minimum respirator protection factor specified in 29 CFR 1926.62 for the specific trigger task performed.

Air sampling may be conducted as part of an initial exposure assessment of all operations where lead or lead-containing materials are being used, disturbed, or removed and shall be conducted of all trigger task operations. Engineering, administrative, and PPE controls will be increased, as necessary, based on this initial exposure assessment.

- B. Analysis of the sample results shall be in accordance with OSHA ID121, NIOSH 7082, or NIOSH 7105, and shall be conducted by a laboratory certified by the AIHA Environmental Lead Laboratory Accreditation Program (ELLAP) in the analysis of air samples by this procedure.
- C. If sample results and/or the initial exposure assessment, performed in accordance with 29 CFR 1926.62, indicate exposures below the action level, follow the general construction specification section for incidental lead exposure.

1.5 TRAINING REQUIREMENTS

- A. The Subcontractor shall ensure that all employees performing work with or which impacts lead-containing material that applies to this section complete the following training before performing any work involving lead:
 - A.1 Lead Worker Training: Provide lead worker training to all employees who are exposed to lead at levels exceeding the action level and to those who are subject to exposure to lead compounds that cause skin irritation. Lead worker training shall have been conducted within one year of the start of work of this subcontract. Training shall be in accordance with 29 CFR 1926.62 (1)(1)(ii-iv), (1)(2), and (1)(3).

1.6 SUBMITTALS

- A. Initial Exposure Assessment/Air Sampling Plan: Prior to the start of operations where lead or lead-containing materials are being used, disturbed, or removed, submit an exposure assessment to the Participating Site in accordance with subpart 1.04 of this section and 29 CFR 1926.62.
 - A.1 Lead Safety Plan or NID: Submit a corporate lead program and job specific lead safety plan. Submit a lead safety plan to the Participating Site in accordance with section 01 33 00 "Submittals" of these specifications. The safety plan shall serve as a written compliance plan and shall detail the manner, in which the specified work is conducted, and the procedures and equipment to be used to ensure that employees are not exposed to lead above the PEL, facilities are not contaminated, and the environment is protected. Specific items addressed in this plan are as follows:

- A.1.a Negative Initial Determination (NID):
The Subcontractor may establish an NID when it can be demonstrated that the work of this subcontract involving lead cannot result in employee exposure to lead at or above the action level during processing, use, or handling. Demonstration shall be by initial monitoring of a representative sample of employees believed to be exposed to the greatest airborne lead concentrations in the workplace, or by objective data. In lieu of the Lead Safety Plan required in paragraph A.1 above, the Subcontractor may submit an NID in conformance with 29 CFR 1926.62 (d)(3) that is satisfactory to the Participating Site. The Participating Site may require the use of some forms of PPE even for operations for which an NID has been developed. Perform lead work in accordance with the OSHA lead in construction standard, and the guidance given in this section.
- A.1.b A description of equipment, materials, controls, crew size, job responsibilities, and operations and maintenance procedures for each activity in which lead-containing material is used or potentially released. This description shall include a brief project-specific statement of the activities to be performed on site.
- A.1.c A description of specific control methods (e.g., wet methods, use of negative-pressure enclosures, and use of critical barriers and drop cloths).
- A.1.d An administrative control schedule if used as a means of reducing employees' time-weighted average exposure to lead.
- A.1.e Technology considered in reducing exposure to below the OSHA established AL and PEL.
- A.1.f Any pre-established NIDs: Air monitoring or objective data documenting employee exposure on similar work conducted by the Subcontractor in the prior 12 months.
- A.1.g A description of the lead work practice, PPE, and respiratory protection that will be used to control worker exposures. This is to include the use of protective work clothing and equipment, hygiene facilities and practices, and housekeeping practices.
- A.1.h A description of arrangements made among subcontractors on multi-subcontractor work sites to inform affected employees (including bystanders) of potential lead exposures, and to clarify responsibilities with regard to control of those exposures.

- B. Prestart Submittals: Provide the following items to the Participating Site Representative prior to the start of any lead trigger task or other activity which can release airborne lead in excess of the PEL on each project:
- B.1 Copies of a notarized statement by the examining medical doctor certifying the date in which the OSHA required medical examination and blood testing (29 CFR 1926.62) took place, for each employee on the project who is or may be exposed to lead above the action level for any day of the year in accordance with 29 CFR 1926.62.
 - B.2 Record of successful respirator fit testing and training performed by a qualified individual within the previous 12 months, for each employee using a respirator on this project with the employee's name with each record.
 - B.3 Air-sampling plan, as required by subpart 1.04, "Exposure Assessment" above.
 - B.4 Lead Safety Plan, as required by paragraph 1.06.A.1, above.
 - B.5 List of all supervisors and workers intended to be assigned to the project.
 - B.6 Evidence of employee training meeting the requirements of subpart 1.05, above, for all employees who will work on the project.
 - B.7 MSDS for all encapsulants, spray glues, chemicals, and materials to be used on the project.
 - B.8 Evidence of HEPA-filtered equipment certification. See section 01 35 23, subpart 3.17.
 - B.9 The name and address of abatement subcontractor's blood-lead testing laboratory, OSHA-CDC listing, and California certification, if necessary.
 - B.10 The name and address of the Subcontractor's air-monitoring and waste-disposal lead testing laboratories including certifications of accreditation for lead in the EPA ELLAP and AIHA proficiency program for lead.
- C. Daily Submittals: Submit NID records in accordance with 29 CFR 1926.62(d)(5) and/or results of personal air monitoring, (TCLP testing, and any other relevant environmental testing performed on the project site, to the Participating Site Representative and the Participating Site ES&H group within one working day following the day on which the results are available.

D. Closeout Submittals: Submit to the Participating Site Representative and the Participating Site ES&H group the following at project closeout:

D.1 Copies of manifests and receipts acknowledging disposal of all hazardous and nonhazardous waste material from the project showing delivery date, quantity, and appropriate signature of landfill's authorized representative.

D.2 Results of personal air monitoring, TCLP testing, and any other relevant testing performed on the project site.

1.7 PRESTART MEETING

Prior to performing lead work, a prestart meeting will be held between the Participating Site Representative and the Subcontractor to discuss lead work issues outlined in subpart 1.06 of this section.

PART 2 PRODUCTS

2.01 GENERAL

Provide all material, equipment, tools, and devices required to complete the lead work safely.

PART 3 EXECUTION

3.1 PROTECTION

A. Use engineered controls in accordance with subpart 3.02, below, to minimize Subcontractor and Participating Site employee potential for exposure to airborne lead dust.

B. If compliance with the exposure standards specified in these specifications cannot be reasonably achieved with engineered and administrative controls, use PPE to minimize Subcontractor employee exposure to lead. PPE may include disposable coveralls, gloves, head covers, work shoes with disposable covers, respirators, eye protection, and/or other necessary equipment. As an alternative to disposable coveralls, Subcontractor employees may be issued reusable work coveralls. Reusable coveralls shall not be worn home and shall be laundered by the Subcontractor. Reusable clothing shall comply with the requirements of 29 CFR 1926.62 (g)(2). Select PPE to mitigate all exposure hazards, including lead and paint stripper, paint, or lockdown agent that is used.

C. Prior to commencing all work, instruct all workers in all aspects of personal protection, work procedures, emergency evacuation procedures, and use of equipment including procedures unique to this project.

Make all necessary equipment readily available for the employee and enforce the use of the gear that is provided.

- D. Respiratory protection shall meet the requirements of 29 CFR 1910.134 and 29 CFR 1926.62. Use the protection factors given in 29 CFR [1910.134\(d\)\(3\)\(i\)\(A\)](#) on all projects.

3.2 ENGINEERING CONTROLS AND GENERAL WORK PRACTICES

- A. Engineering and administrative controls shall be used regardless of the need to use respiratory protection. Submit a description of the specific control methods (e.g., work process description, wet methods) as part of the lead safety plan:
 - A.1 Exhaust systems at the source of aerosol generation or within the general work area shall be HEPA filtered. Use of power tools with HEPA-filter exhausts are preferred if power tools are used for lead work.
 - A.2 Establishment of a regulated area that will keep unprotected personnel out and prevent the spread of lead dust beyond the boundaries of the area. For work inside buildings, this shall involve erection of critical barriers over ventilation system vents, doors, open areas, and other penetrations. Further, it may be necessary to arrange the ventilation system to place the work area under negative pressure relative to the surrounding areas.
 - A.3 Maintain all surfaces as free as practicable of accumulations of lead by HEPA vacuuming and/or wet wiping.
 - A.4 Use of wet methods.
- B. HEPA-Filtered Equipment Testing: HEPA filtered equipment shall be tested and certified in accordance with section 01 35 23, subpart 3.17, "HEPA Filter Certification".

3.3 ADMINISTRATIVE CONTROLS

- A. Personal Hygienic Practices and Housekeeping: The precautions below apply to areas where work with any potential airborne lead is generated by lead-containing materials, unless otherwise noted:
 - A.1 Do not eat or drink in the designated work area.
 - A.2 Designate separate lunchrooms, food storage and preparation areas, and eating areas to avoid the possibility of ingesting lead. Do not perform lead work in these designated areas.
 - A.3 Wash hands and face before eating, drinking, using tobacco products, or

applying cosmetics.

- A.4 Designate change rooms where employees can segregate street clothes from clothing used for lead work operations that generate airborne lead levels exceeding the PEL.
- A.5 Showers shall be used if the airborne levels are greater than the PEL and for operations for which there is no negative exposure assessment. Unless otherwise specified in the Task Order, use showers as specified in the Special Provisions. For showers provided by the Participating Site, ensure that other employees do not use them while they are potentially contaminated with lead dust. Showers used for lead work shall be decontaminated before use by other Participating Site employees.
- A.6 Ensure that surfaces are as free as practicable of lead dust generated by the activity. Use HEPA-filtered vacuum cleaners and/or wet methods to remove dust and debris. Dry shoveling, blowing, and sweeping are prohibited. Contaminated surfaces shall be cleaned to visibly dust-free levels.
- A.7 Promptly place lead-containing demolition or renovation debris (e.g., gypsum wallboard) in plastic bags or other sealable containers. Do not allow debris to accumulate in the workspace.
- B. Signs: Post signs, worded as described below, at all likely entrances to areas where any lead trigger task or other activity which can release airborne lead in excess of the PEL and for which there is no NID is being conducted. These signs shall be well illuminated so that they are easily visible to employees and visitors.

WARNING LEAD WORK AREA POISON
NO SMOKING OR EATING

3.4 SURFACE CONTAMINATION SAMPLING

Surface Contamination Limits: When lead-containing materials are disturbed such that an aerosol is generated, residual surface contamination may pose a hazard to people who subsequently occupy the area; clean contaminated surfaces sufficiently to visibly dust free levels. The Participating Site may require collection of pre and post surface wipe samples to confirm adequate clean-up has been performed.

3.5 WASTE HANDLING

Until analytical results are available, segregate all waste materials (including water) and treat as potentially hazardous. Contact the Participating Site Representative for the proper management of hazardous waste. The Participating Site will dispose of all hazardous waste generated from work performed at Participating Site facilities.

3.6 INSPECTIONS CONDUCTED BY THE PARTICIPATING SITE

The Participating Site will conduct a variety of inspections of the work site to ensure compliance with the provisions of this document and applicable laws and regulations.

END OF SECTION

This page intentionally left blank

SECTION 01 35 23 23 — RADIOLOGICAL SAFETY CRITERIA

PART 1 GENERAL

1.1 SCOPE

This section defines safety criteria and practices for personnel protection from all sources of radioactive contamination or radiation that may be present in the construction area. It also defines work restrictions that may be imposed, and the requirements for handling and removal of all materials and equipment now inside or introduced into the entire construction area.

1.2 BACKGROUND

Certain buildings at DOE/NNSA sites have been used for several years for experimental work with radioactive materials. As a result, some limited amount of residual contamination may be present. Construction work in such areas could uncover or open areas of radioactive contamination that would require the use of protective clothing and/or other equipment.

Also, there are ongoing operations at these sites that involve handling and movement of radiological material and/or the use of radiation generating devices. While at Participating Sites, the Subcontractor shall assure its personnel recognize radiological postings and can respond appropriately for their safety and the safety of co-workers.

1.3 SUPPORT

The Participating Site will provide Health and Safety (H&S) technician support and safety support and surveillance, including decontaminations, safety evaluations and radiological monitoring, as required.

1.4 OPERATIONAL REQUIREMENTS

A. Radiation and other safety protection rules and guides for Subcontractor personnel shall be the same as for Participating Site employees. General Employee Radiation Training (GERT) is provided to all Subcontractor employees as a part of their general site orientation training. Subcontractor employees shall adhere to the limitations and restrictions concerning entry into and work within posted radiological areas and radioactive material areas. The following requirements and work practices are provided.

A.1 The Participating Site will provide a mandatory briefing and demonstration for all workers before they start on the jobsite. The Participating Site personnel will repeat and/or update this briefing as necessary.

- A.2 Do not remove any materials, tools, documents, or anything brought inside the construction area without being monitored and certified for removal by the Participating Site.
- A.3 Smoking, eating, drinking, and the use of chewing gum or tobacco is not allowed in any radiologically-posted areas (e.g., radiation areas, contamination areas, radioactive material areas, and like areas).
- A.4 No radioactive materials or radiation generating devices shall be brought onto the Participating Site property without specific written permission from the Participating Site.
- A.5 Personnel shall wear dosimeters as provided by the Participating Site.
- A.6 Subcontractors and their personnel are subject to both civil and criminal penalty aspects of compliance with 10 CFR 835 “Occupational Radiation Protection.”

1.5 CONSTRUCTION TIME SCHEDULE

No time extension will be allowed for the radiological safety briefings of Subcontractor personnel that were defined in subparagraph 1.04.A.1 of this section.

PART 2 PRODUCTS

Not used

PART 3 EXECUTION

Not used

END OF SECTION

SECTION 01 35 43 — ENVIRONMENTAL PROTECTION

PART 1 GENERAL

1.1 ENVIRONMENTAL MANAGEMENT SYSTEM

- A. All Subcontractors shall perform the work in a manner that supports a commitment to be a responsible steward of the environmental resources through the implementation of the Participating Site's Environmental Management System (EMS) by incorporating the following actions into planning and conducting the work:
 - A.1 Protection of the air, water, land, and other natural and cultural resources
 - A.2 Compliance with all applicable environmental requirements
 - A.3 Pollution prevention, waste minimization, and resource conservation practices

1.2 STORM WATER POLLUTION PREVENTION

- A. Storm Water Pollution Prevention Plan (SWPPP): Maintain continual storm water pollution prevention and perform all work in accordance with the Participating Site's Industrial Activity SWPPP and storm water permit to ensure no pollutants are discharged into the storm drainage system. Failure to comply may result in the Participating Site Representative halting work until the Subcontractor performs remedial action. Copies of the Participating Site's site-wide SWPPP and current industrial storm water permit and best management practices are available for Subcontractor review upon request. Refer to attachments at the end of this section for Best Management Practices (BMPs) applicable to work at the LLNL only.

NOTE: The following four paragraphs are applicable to projects involving land disturbance of less than one acre in area or outdoor work (including staging), projects with potential for storm water impact, and/or projects determined to be environmentally significant.

- B. The Subcontractor may substitute alternate pollution prevention measures for those identified in the Participating Site's SWPPP. Submit alternate measures for the Participating Site's for advance approval. The Participating Site Representative's acceptance of alternate pollution prevention measures will not relieve the Subcontractor of responsibility for the quality and adequacy of the measures or Subcontractor's implementation of them. Such acceptance does not warrant, acknowledge, or admit the quality and adequacy of the alternate pollution prevention measures.
- C. Provide all materials and labor required to implement and maintain pollution prevention measures.

- D. If pollution is leaving the project site, implement necessary corrective measures. Failure to comply with the requirements of the SWPPP may result in criminal and civil liability of the Subcontractor under the Clean Water Act.
- E. When rain is expected (a greater than 50% chance of rain), all materials exposed to rain shall be covered with plastic and the construction site shall be made water-tight.
- F. Coordinate any required drainage of water with the Participating Site Representative.

1.3 AIR EMISSIONS

- A. Dust Control: Perform dust control as required for the alleviation and prevention of any dust nuisance at, or in the vicinity of, the construction site as it pertains to its work. "Dust nuisance" is defined as airborne soil in sufficient quantity to be visible at any building or location adjacent to the construction site. Methods of dust control shall include:
 - A.1 Spraying water on loose soil that may become airborne
 - A.2 Covering all stockpiled excavated material containing soil to preclude wind and water erosion and dispersal during storage
- B. Equipment Emissions:
 - B.1 Ensure all stationary or portable equipment (e.g., generator, air compressors, lifts, etc.) with internal combustion engines rated greater than 50 horsepower is permitted in accordance with the applicable state and local jurisdiction such as the Bay Area Air Quality Management District (BAAQMD for sites in California other than Site 300) or California Air Resources Board (CARB) (for Site 300).
 - B.2 Ensure all products used and work conducted is in compliance with the applicable state and local jurisdiction such as the BAAQMD or San Joaquin Valley Unified Air Pollution Control District (SJVUAPCD) regulations and the air permits issued to specific facilities in which work is performed. Request list of applicable air permits if needed. The Subcontractor shall supply all required information.
 - B.3 All persons removing, installing or otherwise working with equipment containing refrigerants shall be certified in accordance with Section 608 of the Clean Air Act.

The equipment used for refrigerant recovery shall also be certified in accordance with Section 608 of the Clean Air Act, Subcontractor shall comply with the venting prohibition, service practice requirements, leak repair, safe disposal, and record keeping requirements of Section 608. All maintenance and equipment records pertaining to refrigeration units including but not limited to personnel training and certifications, equipment calibration, calibration procedures, and certifications shall be maintained by the subcontractor and made available to the Participating Site upon request. Subcontractor shall also comply with any local or State regulations regarding working with or handling refrigerants.

1.4 MATERIAL AND WASTE DISCHARGES

- A. Do not discharge hazardous materials or wastes into the environment (i.e., air, soil, surface water, and groundwater). Protect all routes of entry to the environment, including direct discharges into air, soil, surface water, storm sewer, sanitary sewer, wells, and drainage channels from construction activities. This shall be achieved by the safe and proper use and storage of tools, equipment, and materials. Inspect construction equipment and vehicles daily for leaks of fuel, engine coolant, and hydraulic fluid. Contain, repair, and immediately report any leaks to the Participating Site Representative. Immediately report to the Participating Site Representative any accidental discharges into the environment. Clean up all discharges into the environment according to the guidance provided by the applicable site's Environmental, Safety, and Health organization representatives. Report all leaks and corrective actions taken to the Participating Site Representative and to LLNS.
- B. Discharges to Sanitary Sewer: Do not discharge any hazardous chemicals into the retention or sanitary system. All discharges to the sanitary sewer system must be approved by Participating Site Representative and the applicable Participating Site Environmental, Safety, and Health organization representatives. Report all discharges to sanitary sewer and correction actions taken to the Participating Site Representative and LLNS.
- C. Discharges to Ground:
 - C.1 Excess concrete may be dumped only in lined excavation pits in locations identified and approved by the Participating Site Representative (not to ground). The Subcontractor shall remove all dried, excess concrete for proper disposal off site and report the total quantity dispose of and/or recycled to the Participating Site Representative and LLNS.
 - C.2 Wash water from cleaning concrete trucks and concrete handling equipment will only be discharged in properly established evaporation pits identified and approved by the Participating Site Representative.

- C.3 Comply with all Spill Prevention, Control, and Countermeasure (SPCC) requirements in 40 CFR 112 including, but not limited to: storage of all oil and petroleum containers (e.g., gas and diesel) 55 gallons and larger in secondary containment sized to the largest container plus four inches of freeboard; monthly inspection of all oil containers 55 gallons and larger; daily inspection of fueling tanks 55 gallons and larger; maintenance of appropriate spill response materials, and; the prevention and/or containment (e.g., drip pans) of leaking equipment.
- C.4 Oil container inspectors and oil handlers (personnel moving or filling oil containers) must provide the Participating Site Representative with documentation of SPCC training. An annual training refresher is required to be taken by oil handling personnel and must be provided either by the applicable site or the Subcontractor. The Subcontractor will be required to ensure that all aspects of the SPCC training are implemented on the construction site. Copies of the applicable site's site-wide SPCC Plan are available for Subcontractor review upon request.
- C.5 Provide all required inspections to the Participating Site Representative at a regular frequency or immediately if a spill or leak has occurred.

1.5 PROTECTION OF CULTURAL OR PALEONTOLOGICAL RESOURCES

- A. Participating Sites will clearly mark known cultural or paleontological resource areas within construction zones by staking, fencing, and pink/black diagonally-striped flagging. Avoid these areas during construction. If cultural or paleontological resources are unearthed during construction activities, immediately stop all work within 50 feet of the find until the Participating Site Representative has assessed it and issued Notice to Proceed.
 - A.1 Examples of cultural resources include:
 - A.1.a Prehistoric cultural deposits such as obsidian or chert flakes or tools; ground- stone mortars, slabs, or pestles; cultural deposits of shell or bone; beads, clothing or woven articles; locally darkened midden (trash) soils; and human interments.
 - A.1.b Historic-period cultural materials such as foundations or other structural remains; bottles, nails, barbed wire, ceramic pieces, buttons, weathered boards, and tin cans; refuse deposits; backfilled wells or privies; glass and pottery.
 - A.2 Examples of paleontological resources include Fossils; bones not of human origin.

- B. The Archaeological Resources Protection Act (ARPA) and the Antiquities Act regulate the protection and excavation of cultural and paleontological resources. Under no circumstances may unauthorized individuals remove or disturb any such resources. If discovered, leave in place, note their location, and immediately notify the Participating Site Representative.

1.6 PROTECTION OF BIOLOGICAL RESOURCES

The Participating Site Representative shall provide project specific avoidance and minimization measures for activities in naturalized or wildland areas. In addition, any project that may impact nesting birds (e.g., tree removal or building demolition) may be required to implement restrictive measures to protect nest sites.

- A. Open Excavations: Protect wildlife from entrapment in steep-walled excavations greater than 1-foot deep as follows:
 - A.1 Cover excavations completely at the end of each working day, or
 - A.2 Provide excavations with animal escape ramps constructed of earth fill (>1 foot) or wooden planks (>2 feet). Earth ramps should be used for excavations between 1 and 2 feet in depth.
 - A.3 Before excavations are filled, thoroughly inspect them for trapped animals. Contact the Participating Site Representative to obtain the assistance of a site wildlife biologist to free trapped animals.
- B. If an Endangered Species Awareness briefing is required prior to initiating work, then the Subcontractor shall have all its laborers, craftsman, supervisors, and managers directly involved in this project attend the briefing.
- C. Work performed in the vicinity of endangered or threatened species nesting areas during breeding season must be controlled to ensure noise or activities do not impact the species.
- D. All workers shall ensure their food scraps, paper wrappers, food containers, cans, bottles, and other trash from the project area are deposited in covered closed trash containers that are not accessible by wildlife.
- E. Feeding of any animals at any site is prohibited.
- F. Subcontractors may not bring any animal to any site.
- G. Exclusion Zones: Do not bring construction activities into known or demarcated areas inhabited by local species of importance. Participating Site wildlife biologists will identify such areas. While at the LLNL, the exclusion zones are as follows:

- G.1 Kit Fox, American Badger, Burrowing Owl Dens, or nest sites: Buffer zones with 750, 300-, 200-, 50-, or 25-foot radii will be surrounded by exclusion fencing consisting of stakes and pink/black diagonally-striped flagging (or possibly with rope or cord).
- G.2 Elderberry Bushes: 300-foot radius buffer zone will be indicated by regularly placed signs or pink/black diagonally-striped flagging around the zone perimeter.
- G.3 Nest Sites: Buffer zones with 750, 300-, 200-, 50-, or 25-foot radii will be surrounded by exclusion fencing consisting of stakes and pink/black diagonally-striped flagging (or possibly with signage).
- H. If any identified endangered species is discovered in the LLNS construction area at any time, the Subcontractor shall immediately cease all work in that area and contact the Participating Site Representative.
- I. Implement appropriate erosion control measures as identified by the Participating Site Representative, such as native seeding and burlap straw wattles. Do not use materials containing plastic monofilament, nylon net, plastic net or photodegradable netting.
- J. Install exclusionary fencing, if required by the Participating Site Representative, surrounding the project site prior to the start of work to preclude the movement of wildlife into the project site. Use a silt fence 18-inches high and held in place by sandbags, or trenched into the ground or equivalent structures.

1.7 CONSERVATION OF ENERGY AND WATER

- A. To the maximum extent practicable, the Subcontractor shall implement conservation practices that will reduce the consumption of water and electricity. Reduction practices may include:
 - A.1 Water Use/Consumption:
 - A.1.a Reduce site-provided potable water use through signage and shutting off water sources at night to minimize leakage.
 - A.1.b Turn off water source when not in use.
 - A.1.c Use water efficient products in work activities, where feasible.
 - A.2 Electrical Energy Use: Turn off electrical powered items (e.g., tools, office equipment, lights) when not in use.

1.8 ASBESTOS

Existing Asbestos: Unless stated otherwise in the Task Order, LLNS does not anticipate that asbestos will be found in existing materials associated with work to be accomplished. However, if asbestos- containing materials (ACMs) are encountered, immediately stop work, notify the Participating Site Representative, and wait for further direction regarding resumption of the work.

1.9 LEAD

- A. The Subcontractor is hereby notified that lead-contaminated materials may be found in materials associated with work to be accomplished under this subcontract. Refer to section 01 35 23.21, “Lead Work Exposure Protection” for further information.
- B. LLNS tracks the amount of lead processed and disposed as required by Federal Emergency Planning and Community Right-to-Know Act (EPCRA) Section 313 reporting regulations. The Subcontractor is responsible for documenting the amount of lead (weight) handled and for submitting the documentation to the Participating Site Representative and LLNS.

1.10 DISPOSAL OF EXCESS SOIL, ASPHALT, CONCRETE, AND OTHER MATERIALS

- A. Disposal and Reuse of Excavated and/or Demolished Materials (asphalt, soil, concrete, and other materials):
 - A.1 Sampling and Evaluation:
 - A.1.a Sample and evaluate all materials resulting from excavating on the project site prior to the Subcontractor removing them from the site.
 - A.1.b To facilitate sampling and evaluation, arrange for and be responsible for temporary staging of the materials at the jobsite until disposal characterization can be completed (usually within 45 days from placement). Stockpile such materials in separate piles. Stake and identify each pile and separate all piles by location. Place the materials on and cover with plastic sheeting at designated location and secure against displacement until such materials are tested and approved for disposal.
 - A.1.c The Participating Site Representative will provide guidance on how to manage the materials when the analytical results have been received and evaluated.

- A.1.a Disposal of such materials demonstrating visual/detectable contamination shall be coordinated with the Participating Site Representative.
- A.2 Clean Soil: Reuse excavated clean soil materials on the Participating Site.
- B. Solid Waste Management:
 - B.1 Prepare a Solid Waste Management Plan (SWMP) utilizing the attached form (attachment 01 35 43-2) and submit it to the Participating Site Representative and LLNS. The SWMP shall include the nonhazardous construction and/or demolition solid waste components (e.g., wood and metals by type) and their proposed disposition (i.e., solid waste disposal or recycling).
 - B.2 Recycling and solid waste diversion for construction waste and municipal waste generated during the project is encouraged. The Subcontractor shall use scrap metal, paper and cardboard recycling bins, where available, to reduce the amount of municipal waste generated.
- C. Hazardous Waste:
 - C.1 The Subcontractor shall be responsible for all wastes generated from hazardous materials used by the Subcontractor, or its lower-tier subcontractors. The Subcontractor shall store, handle, and dispose of such wastes in accordance with applicable federal, state, local environmental regulations, and the Subcontractor's Safety Plan. These wastes may include, but are not limited to, batteries, paints, solvents, oils, and greases as well as their empty containers. All waste (e.g., spent hazardous materials, spill cleanup, and like items) generated during performance of the work shall be evaluated by the Subcontractor according to the requirements in CCR Title 22 Section 66261 and 66262.34 for sites located in California and according to the applicable federal, state, and local regulations, laws, and requirements for sites located in states other than California to determine if it meets the definition of a hazardous waste.
 - C.2 The debris that is characterized by the Participating Site as hazardous waste shall be placed in Participating Site - furnished containers for Participating Site disposal. Prior to the handling of such material, contact the Participating Site Representative for direction.
 - C.3 All hazardous waste will be managed according to the requirements in CCR Title 22 Section 66262.34 for sites located in California and the applicable federal, state, and local regulations, laws, and requirements for sites located in states other than California.

Equipment that uses or contains refrigerant shall be managed through certified appliance recyclers in compliance with 40 CFR.

1.11 SUBCONTRACTOR USE AND MANAGEMENT OF NONHAZARDOUS AND HAZARDOUS MATERIALS

A. Nonhazardous Materials Use:

A.1 The Subcontractor shall, to the maximum extent possible without conflicting with the technical requirements of the subcontract, reduce or eliminate the use and release of certain toxic and hazardous chemicals and materials through the following:

A.1.a Subcontractors are encouraged to use more environmentally benign solvents and solvent-free alternative systems that reduce or eliminate the use of hazardous substances and/or the generation of hazardous waste. The Subcontractor should also purchase hazardous materials in container sizes and amounts that minimize the amount of excess material generated by the project.

A.1.b The Subcontractor is encouraged to reuse and/or recycle surplus commodities and by-products.

A.1.c The Subcontractor shall implement appropriate management practices for nonhazardous and hazardous materials brought on-site to comply with federal, state, and local regulations including but not limited to the following: (a) Do not store materials or waste near storm drainage systems, (b) Use of secondary containment berms for containers of liquid materials, (c) Performing inspection of storage areas, (d) Appropriate labeling of containers.

B. Hazardous Materials Use:

B.1 The use of certain hazardous materials must be tracked and reported to federal and state agencies. The Subcontractor shall discuss with the Participating Site Representative the types of hazardous materials to be used in work activities to determine if any materials must be tracked. The Subcontractor shall maintain all tracking documents identified by the Participating Site Representative and provide the documents to the Participating Site Representative when the work activity is completed.

B.2 The Subcontractor is encouraged to purchase hazardous materials in container sizes and amounts that minimize the amount of excess material generated by the work.

- B.3 Safety Data Sheets (SDS): The Subcontractor shall submit material safety data sheets to the Participating Site Representative for all chemicals, oils, solvents, paints, epoxies, adhesives, petrochemicals, or similar materials to be used on site.
- B.4 The Subcontractor shall maintain copies of these SDS in a readily accessible location on-site. Store materials in containers in accordance with the requirements of the SDS within the construction boundary or as directed by the Participating Site Representative in accordance with SWPPP. Remove and dispose of all such materials not incorporated in the work in accordance with the applicable federal, state, and local regulations.
- B.5 Hazardous Materials Inventory: The Subcontractor shall also complete and submit to the Participating Site Representative the Hazardous Material Inventory form attachment 01 35 43-3. Copies of the completed forms shall be retained, by the Subcontractor, with the MSDS for the work. If any hazardous materials required by the specifications are to remain on site at the end of the project, advise the Participating Site Representative.
- B.6 Transportation of Hazardous Materials: The Subcontractor shall comply with applicable federal and state regulations when transporting hazardous materials to the Participating Site. The Subcontractor shall comply with all posted traffic signs and speed limits.

1.13 CONTROLLED ITEMS AND MATERIALS

- A. The Subcontractor shall not use or bring any of the controlled items or materials listed without prior written approval from the Participating Site.
 - A.1 Asbestos products
 - A.2 Lead or lead-based paint materials (defined as having greater than 600 ppm lead)
 - A.3 Hazardous materials with SDS (See paragraph 1.11.B.3)
 - A.4 Corrosive or toxic chemicals
 - A.5 Flammable or combustible liquids
 - A.6 Radioactive materials
 - A.7 Radiation generating devices
 - A.8 Non-ionizing radiation generating devices
 - A.9 Explosives

A.10 Thoriated welding rods

PART 2 PRODUCTS

Not used

PART 3 EXECUTION

Not used

END OF SECTION
(Attachments 01 35 43-1 through -3 follow)

Attachment 01 35 43-1

LLNL Best Management Practices (BMPs) for Land Disturbance Less than 1 acre.

PURPOSE

The requirements in this document are to ensure that LLNL non-industrial facilities and activities do not negatively affect storm water quality and receiving waters as required by the San Francisco Bay Region Municipal Regional Stormwater Permit Order No. R2-2009-0074 for the Livermore Site and the Phase II Small MS4 General Permit for Site 300. The portion of the MS4 permit that best describes the activities at Site 300 is “Non-Traditional Small MS4 Permittees” 40 CFR 122.26(b)(16). The Storm Water Pollution Prevention Plans for the Livermore site and site 300, document storm water requirements for the Industrial General Permit regulated portions of LLNL.

SCOPE

These BMPs outlines coverage for the non-industrial portions of LLNL sites, more specifically construction related activities where ground disturbance is less than one acre.

The effort is to prevent or reduce the discharge of pollutants to storm water from building repair, remodeling, construction, demolition and land disturbing activities. This is achieved by using sediment and erosion controls, enclosing or covering building material storage areas, using good housekeeping practices, using nonhazardous or less hazardous alternative products, and training employees. It is the responsibility of the Subcontractor to follow this approach for construction areas and phases of construction, including laydown and storage areas.

Most of the BMPs discussed in this chapter are temporary in nature and are specific to construction and ground disturbing activities. Subcontractors performing work onsite are responsible for implementing BMPs. Where applicable, use BMPs identified in the most recent Stormwater Best Management Practice Handbook: Construction (CASQA).

REQUIREMENTS

These BMPs include, but are not limited to the following:

- Use sediment control techniques when bare soil is temporarily exposed. See SE factsheet series in Stormwater Best Management Practice Handbook: Construction (CASQA).
- Use soil erosion control techniques when practical where bare ground is temporarily exposed. See EC factsheet series in Stormwater Best Management Practice Handbook: Construction (CASQA). Erosion control rolls, mats, or other similar materials containing monofilament, thin plastic thread or plastic netting may not be used at the project site.
- Use permanent soil erosion control techniques in areas where buildings are removed and not replaced (e.g., landscaping, hydroseeding, mulching, or graveling).

- Enclose painting operations, as appropriate, to be consistent with local air quality regulations and the Occupational Safety and Health Act (OSHA).
- Cover and properly store materials of particular concern (e.g., soil piles, chemical storage, paints) that are exposed to weather, especially during the rainy season. Limit the use of plastic materials when more sustainable, environmentally friendly alternatives exist. Where plastics materials are deemed necessary, consider the use of plastic materials resistant to solar degradation.
- Properly store and dispose of waste materials generated from the activity. See Factsheet WM-5 in Stormwater Best Management Practice Handbook: Construction (CASQA).
- Provide spill response training for personnel who handle hazardous materials.
- Maintain good housekeeping practices while work is underway and remove debris in a timely manner.
- Prevent discharges of non-permitted wastewater to the storm water drainage system.
- Protect nearby storm drains to minimize the chance of inadvertent discharge of construction materials or sediment. See Factsheet SE-10 in Stormwater Best Management Practice Handbook: Construction (CASQA).
- Designate an appropriate concrete wash out area for trucks. See Factsheet WM-8 in Stormwater Best Management Practice Handbook: Construction (CASQA).
- Clean any sediment or debris from the storm water drainage system in the immediate vicinity of the construction activities after those activities are completed.
- Filter or settle sediment-laden runoff prior to discharge (avoid use of straw bales).
- Provide effective stabilization for disturbed soils and other erodible areas prior to a forecasted storm.
- Maintain effective perimeter controls and stabilize site entrances/exits to sufficiently control discharges of erodible materials from discharging or being tracked off the site. In the event that track out occurs, street sweep as necessary. See Factsheet TC-2 in Stormwater Best Management Practice Handbook: Construction (CASQA).
- Divert run-on and storm water generated off site away from disturbed areas onsite.
- Implement effective wind erosion controls.
- Wash and clean vehicles and equipment in designated area and prevent pollutants from discharging into storm water. See Factsheet NS-08 in Stormwater Best Management Practice Handbook: Construction (CASQA).
- If re-fueling is necessary onsite, fuel vehicles in designated location. Design procedures and practices to prevent fuel spills and leaks, and reduce and eliminate contamination of storm water. See Factsheet NS-09 in Stormwater Best Management Practice Handbook: Construction (CASQA).

This page intentionally left blank

Attachment 01 35 43-3

Hazardous Material Inventory

Project information:

Project Name:	Subcontract No.:
Est. Project Start Date:	Est. Project End Date:

Instructions:

1. Please list hazardous materials below for which the manufacturer or producer has prepared a Safety Data Sheet (SDS).
2. Indicate the quantity of each hazardous material (pounds, gallons, and the like) to be handled at the jobsite.
3. Provide a completed copy of this inventory form to the Participating Site Representative.
4. Notify the Participating Site Representative (at LLNL, ChemTrack Hotline on ext.4-4404) if any materials will be left on site after the project is completed.

Hazardous Material Inventory

Subcontractor Name:	Date:
Contact Name:	Telephone No.:

Material	Quantity	Material	Quantity

SECTION 01 40 00 — QUALITY REQUIREMENTS

PART 1 GENERAL

1.1 SECTION INCLUDES

- A. Basis for Acceptance
- B. Quality Assurance
- C. Quality Control
- D. Materials Inspection
- E. Mockups
- F. Manufacture's Field Services
- G. Repair and Protection
- H. Testing and Inspection Activities

1.2 RELATED REQUIREMENTS

- A. Not used.

1.3 DEFINITIONS

- A. Installer/Applicator/Erector: Subcontractor or another entity engaged by Subcontractor as an employee or lower-tier subcontractor to perform a specific construction operation, including installation, erection, application, assembly, and similar operations.
- B. Mockups: Full-size physical assemblies that are constructed on-site either as freestanding temporary built or as part of permanent construction. Mockups are constructed to verify selections made under sample submittals; to demonstrate aesthetic effects and qualities of materials and execution; to review coordination testing, or operation; to show interface between dissimilar materials; and to demonstrate compliance with specified installation tolerances. Mockups are not samples. Unless otherwise indicated, approved mockups established the standard by which the work will be judged.
 - B.1 Laboratory Mockups: Full-size physical assemblies constructed and tested at testing facility to verify performance characteristics.
 - B.2 Integrated Exterior Mockups: Mockups of the exterior envelope constructed

on-site as freestanding temporary built elements or as part of permanent construction, consisting of multiple products, assemblies, and subassemblies.

- B.3 Room Mockups: Mockups of typical interior spaces complete with wall, floor, and ceiling finishes; doors; windows; millwork; casework; specialties; furnishings and equipment; and lighting.
- C. Product Tests: Tests and inspections that are performed by C. Product Tests: Tests and inspections that are performed by a nationally recognized testing laboratory (NRTL) according to 29 CFR 1910.7, by a testing agency accredited according to National Institute of Standards and Technology's (NIST) National Voluntary Laboratory Accreditation Program (NVLAP), or by a testing agency qualified to conduct product testing and acceptable to authorities having jurisdiction, to establish product performance and compliance with specified requirements.
- D. Source Quality-Control Tests: Tests and inspections that are performed at the source; for example, plant, mill, factory, or shop.
- E. Quality Assurance: Activities, actions, and procedures performed before and during execution of the work to guard against defects and deficiencies and substantiate that proposed construction will comply with requirements.
- F. Quality Control: Tests, inspections, procedures, and related actions to evaluate that actual products incorporated into the work and completed construction comply with requirements. Subcontractor's quality-control services do not include contract administration activities performed by LLNS.

1.4 NATIONALLY RECOGNIZED TESTING LABORATORY (NRTL)

- A. Submit materials and equipment documentation that are tested and listed or labeled by a nationally recognized testing laboratory (NRTL) recognized by the Occupational Safety and Health Administration (OSHA) under 29 CFR 1910.7 such as, but not limited to, Underwriters Laboratories (UL) or FM Global (FM). In cases where no material or equipment of the type specified is NRTL listed, submit relevant technical data regarding the proposed material and equipment, in writing, to LLNS for resolution in accordance with section 01 33 00, "Submittals."
- B. LLNS, solely at its discretion, may require the Subcontractor to submit additional manufacturer's information, such as specific testing procedures used, testing conditions, and other details of the tests.

1.5 BASIS FOR ACCEPTANCE

- A. The basis for inspection/acceptance is compliance with the requirements set forth in the Subcontract and terms and conditions of the Subcontract. LLNS will reject non-conforming products or services. Correct deficiencies within 14 calendar days of the rejection notice in accordance with the applicable clauses. If the Subcontractor cannot correct deficiencies within 14 calendar days, immediately notify the STR of the reason for the delay and provide a proposed corrective action plan within the 14 calendar days.

1.6 TESTING AND INSPECTION

- A. Testing and inspection activities are required to verify compliance with requirements specified or indicated. These services do not relieve Subcontractor of responsibility for compliance with the Subcontract document requirements.
 - A.1 Specific quality- assurance (QA) and quality -control (QC) requirements for individual work results are specified in their respective specification sections. Requirements in individual sections may also cover production of standard products.
 - A.2 Specified tests, inspections, and related actions do not limit Subcontractor's other quality -assurance and quality- control procedures that facilitate compliance with the Subcontract document requirements.
 - A.3 Requirements for subcontractors to provide quality-assurance and quality-control activities required by LLNS, the Government, or authorities having jurisdiction are not limited by provisions of this section.
 - A.4 Specific test and inspection requirements are not specified in this section.

1.7 QUALITY ASSURANCE

- A. Subcontractor Responsibilities
 - A.1 General: Qualifications paragraphs in this article establish the minimal qualification levels required; individual specification sections specify additional requirements.
 - A.2 Manufacture Qualifications: A firm experienced in manufacturing products or systems similar to those indicated for this project and with a record of successful in-service performance, as well as sufficient production capacity to produce required units. As applicable, procure products from manufactures able to meet qualification requirements, warranty requirements, and technical or factory-authorized service representative requirements.

- A.3 Fabricator Qualifications: A firm experienced in producing products similar to those indicated for this project and with a record of successful in-service performance, as well as sufficient production capacity to produce required units.
 - A.4 Install Qualifications: A firm or individual experienced in installing, erecting, applying, or assembling work similar in materials, design, and extent to that indicated for this project, whose work has resulted in construction with a record of successful in-service performance.
 - A.5 Professional Engineer Qualifications: A professional engineer who is legally qualified to practice in the State of California and who experienced in providing engineering services of the kind indicated. Engineering services are defined as those performed for installations for the system, assembly, or product that are similar in material, design, and extent to those indicated for this project.
- B. Subcontractor's Quality Plan
- B.1 See the PRD and Administrative section for quality manager requirements.
 - B.2 Prior to start of construction, prepare and submit a project-specific quality plan for LLNS review and acceptance. Describe Subcontractor's quality assurance and quality control activities and include the following:
 - B.2.a Identify key QA/QC personnel in an organization chart.
 - B.2.b Identify personnel responsible for quality.
 - B.2.c Include a chart showing lines of authority, qualifications (in resume form), duties, and responsibilities of each person assigned to the QA/QC function.
 - B.2.d Identify material sources that require source inspection per Subcontractor documents.
 - B.2.e Describe materials management and control at the source and in the field.
 - B.2.f Describe materials and equipment receipt inspections.
 - B.2.g Describe the coordination procedures for inspection and testing.
 - B.2.h Describe the submittal process for product submittals and material certifications as per Subcontract documents and complying with the submittal section 01 33 00.
 - B.2.i Describe quality control installation activities and process control.
 - B.2.j Describe control of testing and measuring equipment.
 - B.2.k Provide the method for preventing and identifying suspect/counterfeit items.
 - B.2.l Provide the method for identify, tracking, and resolving non-conforming items.

1.8 QUALITY CONTROL

- A. LLNS Responsibilities: Where quality-control services are indicated as LLNS responsibility, LLNS will engage a qualified testing agency to perform these services.
 - A.1 LLNS will furnish Subcontractor with names, addresses, and telephone numbers of testing agencies engaged and a description of types of testing and inspection they are engaged to perform.
- B. Subcontractor Responsibilities: Tests and inspections not explicitly assigned to LLNS are Subcontractor's responsibility. Perform additional quality-control activities, whether specified or not, to verify and document that the work complies with requirements.
 - B.1 Unless otherwise indicated, provide quality-control services specified and those required by authorities having justification. Perform quality-control services required of Subcontractor by authorities having jurisdiction, whether specified or not.
 - B.2 Engage a qualified testing agency to perform quality-control services as indicated in the PRD and other specification sections. Do not employ same entity engaged by LLNS, unless agreed to in writing by LLNS.
 - B.3 Notify testing agencies and STR at least 72 hours in advance of time when work that requires testing or inspection will be performed.
 - B.4 Where quality-control services are indicated as Subcontractor's responsibility, submit a certified written report, in duplicate, for each quality-control service.
 - B.5 Testing and inspection requested by Subcontractor and not required by the Subcontractor documents are Subcontractor's responsibility.
- C. Retesting/Re-inspecting: Regardless of whether original tests or inspections were Subcontractor's responsibilities, provide quality-control services, including retesting and re-inspecting, for construction that replaced work that failed to comply with Subcontract documents.
- D. Coordination: Coordinate sequence of activities to accommodate required quality-assurance and quality-control services with a minimum of delay and to avoid necessity of removing and replacing construction to accommodate testing and inspection.
- E. For design-build projects, the engineer-of-record for each discipline and the architect-of-record must routinely visit the construction site to observe the process

and construction of the project to assure quality and adherence to the subcontract documents. See the PRD for the frequency of visits.

1.9 MATERIAL INSPECTION

- A. LLNS prohibits suspect and counterfeit materials under the general provisions clause titled “Quality of Materials and Supplies.” LLNS may conduct periodic inspections of Subcontractor materials for compliance.
- B. Subcontractor Examination
 - B.1 Promptly examine shipments to ensure that products comply with requirements, quantities are correct, and products are undamaged.
 - B.2 Receive LLNS-furnished equipment/materials shipped to the jobsite and examine them in accordance with the above requirements.

1.10 MOCKUPS

- A. When required by individual technical specifications section, erect a complete, full-scale mockup of assembly at the project site.
- B. LLNS or the designated testing laboratory will perform tests specified in the *Project Requirements Document* (PRD) and in accordance with this section. The accepted mockup becomes the comparison standard for the remaining work.
- C. Remove mockup and clear area at completion, when approved by LLNS.

1.11 MANUFACTURER’S FIELD SERVICES

- A. When specified in the PRD and other specifications, require that the supplier/manufacture provided qualified personnel to observe field conditions, conditions of surfaces and installation, quality of workmanship, startup of equipment as applicable, and to make appropriate recommendations.
- B. Submit the representative’s written report, which lists observation and recommendations, to LLNS.

PART 2 – PRODUCTS

Not used

PART 3 – EXECUTION

3.1 TEST AND INSPECTION LOG

- A. Test and Inspection Log: Prepare a record of tests and inspections. Include the following:
 - A.1 Date test or inspection was conducted.
 - A.2 Description of the Work tested or inspected.
 - A.3 Date test or inspection results were transmitted to Architect.
- B. Maintain log at project site. Post changes and revisions as they occur. Provide access to test and inspection log for LLNS's reference during normal working hours.
- C. Submit log at project close-out as part of project record documents.

3.2 REPAIR AND PROTECTION

- A. General: On completion of testing, inspection, sample taking, and similar services, repair damaged construction and restore substrates and finishes.

Provide materials and comply with installation requirements specified in other specifications sections or matching existing substrates and finishes. Restore patched areas and extend restoration into adjoining areas with durable seams that are invisible as possible. Comply with the Subcontract document requirements for cutting and patching.

- B. Protect construction exposed by or for quality-control services activities.
- C. Repair and protection are Subcontractor's responsibilities, regardless of the assignment of responsibility for quality-control services.

END OF SECTION 01 40 00

SECTION 01 42 00 — CODES AND STANDARDS

PART 1 GENERAL

1.1 INTRODUCTION

- A. All work performed shall be in accordance with the edition of the codes and standards in effect as of January 1, 2023, unless otherwise noted. Codes and standards listed in the individual specification sections or as shown on the subcontract drawings shall be considered minimum requirements.
 - A.1 Throughout the subcontract documents, reference is made to codes and standards which establish qualities and types of workmanship and materials, and which establish methods for testing and reporting on the pertinent characteristics.
 - A.2 Where materials or workmanship are required by these subcontract documents to meet or exceed the specifically named code or standard, provide materials and workmanship which meet or exceed the specifically named code or standard.

1.2 QUALITY CONTROL

- A. Compliance with Pertinent Codes and Standards: In procuring all items used in this work, verify the detailed requirements of the specifically named codes and standards and verify that the items procured for use in this work meet or exceed the specified requirements.
- B. Rejection of Nonconforming Items: The Participating Site may reject items incorporated into the work which fail to meet the specified minimum requirements. The Participating Site may also accept nonconforming items subject to an adjustment in the subcontract amount as accepted by LLNS.
- C. Nationally Recognized Testing Laboratory (NRTL):

Materials shall be tested and listed or labeled by a nationally recognized testing laboratory (NRTL) recognized by the Occupational Safety and Health Administration (OSHA) under 29 CFR 1910.7 such as, but not limited to, Underwriters Laboratories (UL) or FM Global (FM). In cases where no material of the type specified is NRTL listed, submit all relevant technical data regarding the proposed material, in writing, to the Participating Site Representative for resolution in accordance with section 01 33 00“Submittals”.The Participating Site may, solely at its option, require the Subcontractor to submit additional manufacturer's information, such as specific testing procedures used, conditions under which testing was performed, and/or other details of the tests.

1.3 CODES AND STANDARDS

- A. When required by these specifications, comply with the codes and standards promulgated by the following agencies and organizations and those identified in other sections in these Special Provisions. Bring any conflicts between specifications, drawings, and the referenced documents to the attention of the Participating Site and LLNS, in writing, for resolution before taking any related action. Where differences exist between codes and standards, the one with the most stringent requirement, as determined by LLNS, shall apply
- B. Code of Federal Regulations (CFR), including
- | | |
|--------------------------|--|
| 10 CFR 433 | Energy Conservation Standards for the Design and Construction of New Federal Commercial and Multi-Family High-Rise Residential Buildings |
| 10 CFR 851 | Worker Safety and Health Program Department of Energy |
| 29 CFR 1904 | Parts 1904.4-11, 29-33, 44, and 46; Recording and Reporting Occupational Injuries and Illnesses |
| 29 CFR 1910 | Occupational Safety and Health Standards, Department of Labor |
| 29 CFR 1910.7 | Definition and Requirements for a Nationally Recognized Testing Laboratory |
| 29 CFR 1926 | Safety and Health Regulations for Construction, Department of Labor |
| 40 CFR | Protection of Environment, including |
| 40 CFR Part 82 Subpart F | Protection of Stratospheric Ozone, Recycling and Emissions Reduction |
| 40 CFR Part 261 | Identification and Listing of Hazardous Waste |
| 40 CFR Part 273 | Standards for Universal Waste Management |
| 40 CFR Part 279 | Standard for the Management of Used Oil |
| 41 CFR 101 | Public Contracts and Property Management; Management of Buildings and Grounds: 20.17: Energy Conservation |
| 47 CFR 15 | Telecommunications (FCC rules, Part 15) |
- C. U. S. Department of Energy Directives, Delegations, and Requirements, including

DOE G 413.3-21 Cost Estimating Guide
DOE G 413.3-7A Risk Management Guide
DOE O 420.1C Chg 1 Facility Safety
DOE Order 436.1, *Departmental Sustainability*

D. California Code of Regulations (CCR), for sites located in the State of California

Title 24 Part 2: California Building Code (CBC)
 Part 3: California Electrical Code
 Part 4: California Mechanical Code (CMC)
 Part 5: California Plumbing Code (CPC)
 Part 6: California Energy Code
 Part 9: California Fire Code

2013 Building Energy Efficiency Standards for Residential and Nonresidential Buildings

E. Federal Standards (FED STD), including

FED STD 795 Uniform Federal Accessibility Standards (UFAS)

F. Air Conditioning, Heating and Refrigeration Institute (AHRI)

G. American Concrete Institute

ACI 301 Structural Concrete
ACI 318 Building Code Requirements for Structural Concrete
ACI 347 Formwork for Concrete

H. American Institute of Architects (AIA)

AIA Best Practices, *Design Development Quality Management Phase Checklist*, October 2011

I. American Institute of Steel Construction

AISC M016 Manual of Steel Construction Allowable Stress Design
AISC M020 Manual of Steel Construction Load & Resistance Factor Design
AISC S341 Seismic Provision for Structural Steel Buildings

- J. American National Standards Institute (ANSI), including
 - ANSI A10 Series Safety Requirements for Construction
 - ANSI B30 Series Safety Standards for Cranes and Hoists
 - ANSI Z49.1 Safety in Welding, Cutting, and Allied Processes
 - ANSI Z88.2 American National Standard for Respiratory Protection
- K. American Society of Civil Engineers (ASCE)
 - ASCE 7 Minimum Design Loads for Buildings and Other Structures
- L. American Society of Heating, Refrigerating, and Air-Conditioning Engineers (ASHRAE), including
 - ASHRAE 15 Safety Code for Refrigeration Systems
 - ASHRAE 34 Designation and Safety Classification of Refrigerants
 - ASHRAE 55 Thermal Environmental Conditions for Human Occupancy
 - ASHRAE 62.1 Ventilation for Acceptable Indoor Air Quality
 - ASHRAE 90.1 Energy Efficient Design of New Buildings Except Low-Rise Residential Buildings
 - ASHRAE 135 BACnet – A Data Communication Protocol for Building Automation and Control Networks
 - ASHRAE 189.1 Design of High Performance Green Buildings
- M. American Society of Mechanical Engineers (ASME)
 - ASME BPVC Boiler and Pressure Vessel Code
 - ASME A17.1 Safety Code for Elevators and Escalators
- N. American Society of Professional Estimators (ASPE)
 - Cost Estimating Classification System*
- O. American Society for Testing and Materials (ASTM)
 - Applicable Standards

- P. American Water Works Association (AWWA)
- Q. American Welding Society
 - AWS D1.1 Structural Welding Code – Steel
 - AWS D1.3 Structural Welding Code – Sheet Steel
- R. Associated Air Balance Council (AABC)
- S. Association for the Advancement of Cost Engineering International (ACEC)
- T. Illuminating Engineering Society of North America (IESNA)
- U. Institute of Electrical and Electronics Engineers (IEEE)
- V. International Code Council (ICC)
 - International Building Code
 - International Mechanical Code
 - International Plumbing Code
- W. National Fire Protection Association (NFPA), including
 - NFPA 13 Standard for the Installation of Sprinkler Systems
 - NFPA 70 National Electrical Code
 - NFPA 70E Standard for Electrical Safety in the Workplace
 - NFPA 72 National Fire Alarm Code
 - NFPA 75 Standard for the Fire Protection of Information Technology Equipment
 - NFPA 90A Standard for the Installation of Air Conditioning and Ventilation Systems
 - NFPA 92 Standard for Smoke Control Systems
 - NFPA 101 Life Safety Code
 - NFPA 241 Standard for Safeguarding Construction, Alteration, and Demolition Operations
 - NFPA 255 Standard Method of Test of Surface Burning

Characteristics of Building Materials

- X. National Electrical Manufacturers' Association (NEMA)
- Y. National Environmental Balancing Bureau (NEBB)
- Z. National Sanitation Foundation (NSF)
- AA. Sheetmetal and Air-Conditioning Contractors' National Association (SMACNA)
- BB. Telecommunications Industry Standards
 - TIA/EIA-568 A Commercial Building Telecommunications Cabling Standard
 - TIA/EIA-569 Commercial Building Standard for Telecommunications Pathways and Spaces
 - TIA/EIA-606 Administrative Standard for the Telecommunications Infrastructure of Commercial Buildings
 - TIA/EIA-607 Commercial Building Grounding and Bonding Requirements for Telecommunications
- CC. Underwriters' Laboratories (UL)
- DD. United States Green Building Council Leadership in Energy and Environmental Design (USGBC LEED)
- EE. Refer to individual sections of these Special Provisions for other names and abbreviations of trade associations and standards applicable to specific portions of the work. Other codes or standards may be cited elsewhere in these Special Provisions and shall apply as if repeated here.
- FF. Comply with all applicable federal, state, and local safety, health, and environmental regulations and the Subcontractor's approved safety plan.

PART 2 PRODUCTS

Not used

PART 3 EXECUTION

Not used

END OF SECTION

This page intentionally left blank

SECTION 01 50 00 — TEMPORARY FACILITIES/CONTROLS AND SITE CLEAN UP

PART 1 GENERAL

1.1 SECTION INCLUDES

- A. Temporary electricity, telephone service, water service, sanitary facilities, and ventilation
- B. Barriers
- C. Project site access controls
- D. Traffic control
- E. Protection of installed work
- F. Protection of existing structures and trees
- G. Progress cleaning and waste removal
- H. Field offices, sheds, and break areas
- I. Removal of utilities, facilities, and controls

1.2 REFERENCES

- A. The following documents form a part of these specifications to the extent stated herein.
- B. Bay Area Air Quality Management District (BAAQMD), for Participating Sites located in the State of California
- C. San Joaquin Valley Unified Air Pollution Control District (SJVUAPCD), for Participating Sites located in the State of California, San Joaquin County
- D. American Conference of Governmental Industrial Hygienists (ACGIH)

ACGIH Industrial Ventilation Manual

1.3 TEMPORARY ELECTRICITY

- A. If the Task Order indicates electrical power is not available, provide temporary power such as portable generators, for the Subcontractor's construction purpose. Use of temporary portable generators shall be in accordance with the local air quality management district such as BAAQMD or SJVUAPCD rules and regulations. Permits and/or use of registered inter-district equipment may be required.
- B. If the Task order indicates electrical power will be available to the Subcontractor within 100 feet of the construction site for tools, equipment, lighting, and other construction uses only.
- C. Conditions:
 - C.1 The Subcontractor shall bear the expense of connecting of electricity from the Participating Site on-site sources.
 - C.2 Exercise reasonable care to conserve Participating Site -furnished power and take the following minimal energy conservation measures:
 - C.2.a Turn off all unnecessary construction lights and equipment at the close of each workday.
 - C.2.b Set thermostats in construction office and any other facilities under Subcontractor control at the following: 74°F for cooling and 70°F for heating.
 - C.2.c Install 7-day time clock on construction offices and any other facilities under Subcontractor control that will provide for off-hour as well as weekend electrical power shutdown.
 - C.3 Participating Sites do not guarantee availability of electrical power nor will they be responsible for interruptions in service.
 - C.4 Temporary service installed by and for the Subcontractor shall be removed and utilities restored to their initial condition by the Subcontractor at the completion of the subcontract.
 - C.5 Provide and maintain the electrical power distribution system downstream of Participating Site-furnished electrical service.
- D. All temporary electric power shall be protected by ground fault circuit interrupters. Daisy-chaining of extension cords is not permitted.

1.4 TEMPORARY TELEPHONE SERVICE

- A. Telephone services may not be available at site.

1.5 TEMPORARY WATER SERVICE

- A. Water: Temporary water is available on a limited basis to the Subcontractor.

- A.1 Potable water is the responsibility of the Subcontractor.

- A.2 If the Task Order indicates construction water is available with proper connection to a Participating Site fire hydrant, then the Participating Site will provide adapters on water hydrants designated for Subcontractor use. Provide backflow preventer acceptable to Participating Site Fire Department. Do not remove the adapter installed on the fire hydrant. Exercise reasonable care to conserve Participating Site -supplied water.

1.6 GENERAL SANITATION

The Subcontractor shall ensure that the construction work place conforms to the requirements of 29 CFR 1926.51.

1.7 TEMPORARY SANITARY FACILITIES

Provide temporary sanitary facilities equipped with water suitable for hand-washing.

1.8 TEMPORARY VENTILATION

Ventilate enclosed areas to achieve curing of materials, to dissipate humidity, and to prevent inhalation exposure and potential contamination caused by the generation of dust, fumes, vapors, or gases. Use ventilation to maintain the concentrations of air contaminants below applicable standards. Provide ventilation in accordance with ACGIH "Industrial Ventilation Manual."

1.9 BARRIERS

- A. Provide and maintain suitable temporary barricades, fences, and other structures as required for the protection of public traffic and employees; provide walks around any obstructions; and maintain on or near the construction, sufficient light to protect all personnel from injury. All barricades shall have electrically operated warning lights during hours of darkness. No open-flame lights will be permitted.

- B. Provide protective closure facilities such as roofing, canopies, and/or seals at existing buildings where connections or modifications are being made, to prevent the entry of rain and other weather elements so that equipment, facilities and structure are protected and retained in operating condition.
- C. Protect vehicular traffic, parked vehicles, stored materials, site, and structures from damage.

1.10 PROJECT SITE ACCESS CONTROLS

Establish clear limits of construction area and entry control. Provide entry-control sign-in boards, properly delineated boundaries, list of facility points of contact (FPOCs), access requirements and the like.

1.11 TRAFFIC CONTROL

- A. Give at least 48-hour notice to the Participating Site Representative whenever large shipments or deliveries are expected at the jobsite.
- B. Provide full-time flagman whenever heavy equipment or trucks are crossing or entering onto site roads, parking lots, or pathways.
- C. Develop and submit pedestrian, bicycle, and vehicular traffic control plans for approval where work affects roadway and pathway network. Clearly show location of signs, barricades, flagman and other temporary devices. Account for all phases of construction. Plans must conform with the latest edition of the California Manual on Uniform Traffic Control Devices or applicable Participating Site state requirement.

1.12 PROTECTION OF INSTALLED WORK

- A. Protect installed work and provide special protection where specified in the Task Order or individual specification sections.
- B. Provide temporary and removable protection for installed products. Control activity in immediate work area to prevent damage.

1.13 PROTECTION OF EXISTING STRUCTURES AND TREES

- A. Protect existing structures and all trees and shrubbery to remain against damage. Repair or replace structures, streets, curbs, utilities, and landscaping damaged due to the Subcontractor's construction activities at no increase to the Task Order price. Replace each tree removed or damaged with a boxed specimen with 6-inch minimum trunk diameter of like kind at locations directed by the Participating Site. Provide for temporary watering of existing trees and ground cover where

existing irrigation is disrupted by construction. Replace damaged or removed irrigation at completion of work.

- B. Do not overload load-bearing structural elements, including roofs. Verify adequacy of structural elements to support temporary loads including personnel or equipment used to place loads. Provide written verification, from a civil or structural engineer licensed in the state of the Participating Site, to demonstrate that structural elements are adequate to support all temporary loads that Subcontractor places on roofs, structures, or load-bearing elements.
- C. Ensure that lifting operations will not cause collateral damage to structures, the environment, the materials being lifted, and all utilities, underground or otherwise.
- D. See General Provisions, clause 5, *Permits, Responsibilities, and Assumption of Risk* in the Subcontract documents for requirements if trees, structures, shrubs or other elements are damaged.

1.14 PROGRESS CLEANING AND WASTE REMOVAL

Keep the construction area clean at all times and remove accumulated debris, waste materials, and rubbish each day in accordance with the Subcontractor's solid waste management plan (section 01 35 43 "Environmental Protection").

Assign required manpower to perform clean up and provide dumpsters for rubbish, debris, and nonhazardous waste materials. If, in the opinion of the Participating Site or LLNS, the jobsite has not been kept clean and orderly and presents a potential safety or fire hazard, the Subcontractor may be required to stop work in the affected area and immediately correct the defects at no increase to the Task Order price, including lost time for clean-up effort. Supply sufficient personnel for the time the Subcontractor is performing work on site, to assist in general project site clean-up. Refer to section 01 77 00 "Project Closeout" for final cleaning.

1.15 FIELD OFFICES, SHEDS, AND BREAK AREAS

Provide all temporary storage, office space, and break areas that may be required at the site for the safe and proper storage of tools, materials, and Subcontractor employee use. Locate these temporary facilities where directed by the Participating Site Representative. Provide and maintain trash receptacles with covers. Remove them promptly at completion of work.

1.16 REPAIR AND REMOVAL OF TEMPORARY UTILITIES, FACILITIES, AND CONTROLS

- A. Remove temporary utilities, equipment, facilities, and materials prior to final inspection and as directed by the Participating Site Representative.

- B. Remove temporary underground installations to the minimum depth required or as indicated on the subcontract documents. Grade site as indicated or restore to original condition.
- C. Clean and repair damage caused by work or use of temporary work.
- D. Restore existing and permanent facilities used during construction to original condition.

PART 2 PRODUCTS

Not used

PART 3 EXECUTION

Not used

END OF SECTION

SECTION 01 45 00 — QUALITY CONTROL

PART 1 GENERAL

1.1 SECTION INCLUDES

- A. Material inspection
- B. Mockups
- C. Manufacturers' field services
- D. Testing laboratory services
- E. Schedule of Participating Site -provided inspections and tests

1.2 REFERENCES

- A. The following documents form a part of these specifications to the extent stated herein.
- B. ASTM International (ASTM)
 - ASTM D 698 Laboratory Compaction Characteristics of Soil Using Standard Effort
 - ASTM D 1556 Density and Unit Weight of Soil in Place by the Sand-Cone Method
 - ASTM D 1557 Laboratory Compaction Characteristics Using Modified Effort
 - ASTM D 2829 Sampling and Analysis of Built-Up Roofs
 - ASTM D 3740 Minimum Requirements for Agencies Engaged in the Testing and/or Inspection of Soil and Rock as Used in Engineering Design and Construction
 - ASTM E 329 Agencies Engaged in the Testing and/or Inspection of Materials Used in Construction
- C. National Institute of Standards and Testing (NIST) Applicable Standards

1.3 MATERIAL INSPECTION

- A. Suspect/counterfeit materials are prohibited under the general provisions clause entitled “Quality of Materials and Supplies.” The Participating Site may conduct periodic inspections of Subcontractor materials for compliance.
- B. Subcontractor Examination:
 - B.1 Promptly examine shipments to ensure that products comply with requirements, quantities are correct, and products are undamaged.
 - B.2 Receive Government-furnished equipment/materials shipped to the jobsite and examine them in accordance with the above requirements.

1.4 MOCKUPS

- A. When required by individual technical specifications section, erect complete, full-scale mockup of assembly at project site.
- B. Specified tests will be performed in accordance with this section. Accepted mockup will be a comparison standard for the remaining work.

1.5 MANUFACTURERS’ FIELD SERVICES

- A. When required by Task Order or these Special Provisions require supplier or manufacturer to provide qualified personnel to observe field conditions, conditions of surfaces and installation, quality of workmanship, start-up of equipment, test, adjust, and balance of equipment or services as applicable, and to make appropriate recommendations.
- B. Submit the representative’s written report to the Participating Site Representative and LLNS listing observations and recommendations.

1.6 TESTING LABORATORY SERVICES

- A. The Participating Site will employ and pay for services of an independent testing laboratory to perform inspections, tests, and other services required by the Task Order or these Special Provisions listed in the schedule at the end of this section. Any other tests required by the various sections of these specifications shall be provided and paid for by the Subcontractor.
- B. After each inspection and test, the Participating Site will direct the testing laboratory to promptly submit a copy of the testing laboratory report to the Subcontractor.

The report will include: Date issued, project title and PFN number, name of inspector, date and time of sampling or inspection, identification of product and specifications section, location in the project, type of inspection or test, date of test, results of tests, and conformance with subcontract documents. When requested by the Participating Site, the testing laboratory will provide interpretation of test results.

- C. Cooperate with testing laboratory personnel; provide access to work, furnish tools, samples of materials, design mix, equipment, storage, and assistance as requested.
 - C.1 Deliver to testing laboratory at designated location adequate samples of materials proposed to be used that require testing, together with proposed mix designs.
 - C.2 Notify the Participating Site Representative 48 hours prior to expected time for operations requiring testing services.
 - C.3 Make arrangements with testing laboratory and pay for additional samples and tests performed for the Subcontractor's convenience.
- D. If tests indicate work does not meet specified requirements, remove and replace work at no additional cost to LLNS.

PART 2 PRODUCTS

Not used

PART 3 EXECUTION

Not used

END OF SECTION

This page intentionally left blank

SECTION 01 52 00 — STORAGE AND PROTECTION

PART 1 GENERAL

1.1 SECTION INCLUDES

- A. Transportation and handling
- B. Storage and protection
- C. Repairs and replacements

1.2 TRANSPORTATION AND HANDLING

- A. Transport and handle products in accordance with manufacturer's written instructions.
- B. Provide equipment and personnel to handle products by methods that prevent soiling, disfigurement or damage.
- C. Promptly remove damaged material and unsuitable items from the jobsite and promptly replace with material meeting the specified requirements at no additional cost to LLNS.

1.3 STORAGE AND PROTECTION

- A. Except as directed by the Participating Site Representative, store and protect products in accordance with manufacturers' written instructions.
- B. Store with seals and labels intact and legible.
- C. Store sensitive products in weather-tight, climate controlled, enclosures in an environment favorable to product.
- D. Provide equipment and personnel to store products by methods that prevent soiling, disfigurement, or damage.
- E. Exterior Storage:
 - E.1 For exterior storage of fabricated products, place on supports aboveground.
 - E.2 Cover products subject to deterioration with impervious sheet covering and provisions for water runoff. Provide ventilation to prevent condensation and degradation of products.

- E.3 Arrange storage of products in accordance with section 01 35 43 “Environmental Protection” to permit access for inspection. Periodically inspect to verify products are undamaged and are maintained in acceptable condition.
- E.4 Store loose granular materials on solid flat surfaces in a well-drained area. Prevent mixing with foreign matter.
- E.5 Store all material to prevent contamination of storm water runoff.
- F. When required by Task Order, indicate on-site exterior storage space for Subcontractor materials is not available, provide bonded off-site storage and protection for materials as needed at no additional cost to the Participating Site or LLNS.
- G. Provide protection for finished floor surfaces in traffic areas prior to allowing equipment or materials to be moved over such surfaces.
- H. Maintain finished surfaces clean, unmarred, and suitably protected until accepted by the Participating Site Representative.

1.4 REPAIRS AND REPLACEMENTS

- A. In event of damage, promptly make replacements and repairs as directed by the Participating Site Representative and at no additional cost to the Task Order.
- B. Additional time required to secure replacements and to make repairs will not be considered by the Participating Site Representative to justify an extension in the subcontract time of completion.

PART 2 PRODUCTS

Not used

PART 3 EXECUTION

Not used

END OF SECTION

SECTION 01 77 00 — PROJECT CLOSEOUT

PART 1 GENERAL

1.1 SECTION INCLUDES

- A. Closeout procedures
- B. Final cleaning
- C. Adjusting
- D. Project record documents
- E. General requirements for manuals
- F. Warranties
- G. Spare parts and extra products
- H. Demonstration

1.2 CLOSEOUT PROCEDURES

- A. Submit written certification that subcontract documents have been reviewed, work has been inspected, is complete in accordance with subcontract documents, and is ready for Participating Site Representative and LLNS review and inspection.
- B. Provide submittals to the Participating Site Representative required by the subcontract documents.

1.3 FINAL CLEANING

- A. Execute final cleaning prior to final project assessment.
- B. Clean debris from drainage systems.
- C. Clean site; sweep paved areas; rake clean landscaped surfaces.
- D. Remove waste and surplus materials, rubbish, and construction facilities from the site.

1.4 ADJUSTING

Adjust operating products and equipment to manufacturer's specifications and recommendations, to ensure smooth and unhindered operation.

1.5 PROJECT RECORD DOCUMENTS

A. Preparation of Project Record Documents: Maintain, as a minimum, on site one set of drawings, specifications, addenda, change orders, and other modifications to the subcontract, reviewed submittals, manufacturer's written instructions for assembly, installation and adjusting, and test and inspection reports, including batching records, fabrication travelers, laboratory and field test reports, survey records, and the like.

A.1 Ensure daily entries are complete and accurate. Record information concurrent with construction progress.

A.2 Store project record documents separate from documents used for construction.

B. Drawings: Legibly mark each item to record actual construction. Minimum lettering size on full-size drawings shall be 1/8-inch high, block style, vertical upper case. Do not use paste- on details or mark on the back side of drawings. Include at the minimum, the following:

B.1 Measured depths of foundations in relation to finish first floor datum

B.2 Changes in the horizontal and vertical locations of new and existing underground utilities and appurtenances, referenced by site coordinates or to permanent surface improvements

B.3 Measured locations of building piping and appurtenances concealed in construction, referenced to visible and accessible features of the work

B.4 Field changes of dimensions and details

B.5 Details, especially utilities discovered in the course of work and not on original subcontract drawings or Participating Site-approved design/shop drawings

B.6 Special attention shall be applied to showing changes in the following areas:

- Buried or concealed (inaccessible without demolition) work
- Structural modifications
- Pneumatic, electrical, and electronic control systems

- C. Specifications: Legibly mark and record at each product section description of actual products installed, including the following:
 - C.1 Manufacturer's name and product model and number
 - C.2 Product substitutions or alternates utilized
 - C.3 Changes made by addenda and subcontract modifications

- D. Final Submittal of Project Documents: Prior to final acceptance inspection, submit project record documents, as defined above, to LLNS and the Participating Site. Final submittal shall include the following:
 - D.1 Hard Copy: One complete hard-copy set of full-sized project drawings and specifications, marked-up and augmented with submittals to fully illustrate all revisions made in the course of the work. Hard copies shall be vellum (sepia and bond copies not acceptable).

 - D.2 Electronic Copy – Drawings: Submit updated final project [and submittal] drawings showing all new and revised work.
 - D.2.a Include all nonstandard fonts (.shx file). Special fonts require LLNS approval. Utilize the Participating Site coordinate system for site drawing layouts. Show entities as layer specific with separate text layers.

 - D.2.b Treat linetypes, entities, and colors “BYLAYER” only. Include a layering schedule (uniquely and consistently named for each design discipline) and legend of blocks and symbols used. American Institute of Architects layering guidelines shall apply.

 - D.2.c All Xrefs shall be bound to the drawing.

 - D.2.d Data inserted into the drawing that cannot be bound or OLE'd shall have the same name as the file number. Information that cannot be permanently attached to the drawing shall be saved together.

 - D.2.e Submit each drawing as a separate stand-alone file.

 - D.3 Electronic Copy – Specifications: Submit updated final project specifications in Microsoft Word for Windows.

1.6 GENERAL REQUIREMENTS FOR MANUALS

- A. Quality Assurance: Prepare instructions and data by personnel experienced in maintenance and operation of described products.
- B. Compile operating and maintenance data in the form of manuals appropriate for care and maintenance of products provided under the subcontract and specific information requested in various technical sections of these specifications.
- C. Submittal of Manuals:
 - C.1 Submit two copies of preliminary draft of proposed formats and outlines of contents before start of work. The Participating Site Representative will review draft and return one copy with comments.
 - C.2 Submit two sets of revised final volumes in final form within 10 days after final inspection.
- D. Format:
 - D.1 Prepare data in the form of an instructional manual.
 - D.2 Binders: Electronic copy.
- E. Operation and Maintenance Data Manual Content:
 - E.1 Part 1: Directory, listing names, addresses, and telephone numbers of the Plant Operations Engineer, Subcontractor, lower-tiered subcontractors, and major equipment suppliers.

E.2 Part 2: Operation and maintenance instructions arranged by equipment and or system and subdivided by specification section. For each category, identify names, addresses, and telephone numbers of subcontractors and suppliers. Identify the following:

- Significant design criteria
- Equipment list and description
- Parts list for each component, including recommended spare parts
- Operating instructions
- Maintenance instructions for equipment and systems
- For multiple-energy-source equipment, written lockout/tagout procedures prepared in accordance with 29 CFR 1910.147 (c) (4)

E.3 Part 3: Project documents and certificates including the following:

- Shop drawings, product data, and calculations
- Certificates
- Photocopies of warranties

F. Materials and Finishes Manual Content:

F.1 Building Products, Applied Materials, and Finishes: Include manufacturer and (name, address, phone number) product data, with catalog number, size, composition, and color and texture designations. Provide information for reordering custom manufactured products.

F.2 Instructions for Care and Maintenance: Include manufacturer's recommendations for cleaning agents and methods, precautions against detrimental agents and methods, and recommended schedule for cleaning and maintenance.

F.3 Moisture Protection and Weather Exposed Products: Include product data listing applicable reference standards, chemical composition, and details of installation. Provide recommendations for inspections, maintenance, and repair.

F.4 Additional Requirements: As specified in individual specification sections.

F.5 Provide a listing in table of contents for design data with tabbed fly sheet and space for insertion of data.

1.7 WARRANTIES

- A. The Subcontractor shall submit a warranty/master equipment list as shown in attachment 01 77 00-1 to this section.
- B. Form of Submittals:
 - B.1 Transmit electronically.
 - B.2 Table of Contents: in the sequence of the table of contents of the project manual with each item identified with the number and title of the specification section in which specified and the name of product or work item.
 - B.3 Provide full information using separate typed sheets as necessary. List the Subcontractor, supplier, and manufacturer with name, address, and telephone number of responsible company principal.
- C. Preparation of Submittals:
 - C.1 Obtain warranties, guarantees, bonds, and service and maintenance contracts executed in quadruplicate by responsible Subcontractors, suppliers, and manufacturers, within 14 calendar days after acceptance of the applicable item of work. Except for items put into use with the Participating Site's permission, leave date of beginning of time of warranty until the date of substantial completion is determined.
 - C.2 Provide a copy of each warranty/guarantee and service contract issued. Include an information sheet for Participating Site personnel giving:
 - C.2.a Proper procedures in the event of failure
 - C.2.b Required maintenance information
 - C.2.c Instances which might affect the validity of contracts

- C.3 Verify that documents are in proper form, comply with subcontract documents, contain full information, and are notarized.
- C.4 Co-execute submittals when required.
- C.5 Submit one original, signed copies, of each and an electronic copy.
- D. Timing for Submittals:
 - D.1 For equipment or equipment component parts put into service during construction with LLNS' permission, submit warranty documents within 14 calendar days after equipment is put into service.
 - D.2 Furnish one electronic copy of warranties, guarantees, and bonds from responsible Subcontractors, suppliers, and manufacturers, within 14 calendar days after acceptance of the applicable item of work. Except for items put into use with the Participating Sites' permission, leave date of beginning of time of warranty until the date of acceptance is determined.
- E. Equipment, Subsystem, and Component Warranty: Warranty equipment, subsystems, and manufactured components in accordance with the clause entitled "Warranty of Construction" in the General Provisions except that the warranty period shall not be less than 24 months from the date the item is delivered to the site, or 12 months from the date of first operation, whichever occurs first. The warranty obligation includes field labor and material to remedy the problem, replacement of defective parts, components, and whole equipment items.
- F. Specific Warranties: Specific warranties of construction items, specified in the Task Order Articles shall take precedence over the warranties stated in paragraphs D and E above.

1.8 SPARE PARTS AND EXTRA PRODUCTS

- A. When required by Task Order, provide spare parts and extra products in quantities specified in individual specification sections.
- B. Deliver to project site and place in location as directed by the Participating Site Representative. Obtain proof or receipt prior to submitting final application for payment.

PART 2 PRODUCTS

Not used

PART 3 EXECUTION

3.1 DEMONSTRATION

- A. Before final inspection, instruct designated personnel in operation, adjustment, and maintenance of products, equipment, and systems at agreed upon times.
- B. Use operation and maintenance manuals as basis for instruction. Review contents of manual with personnel in detail to explain all aspects of operation and maintenance.
- C. Prepare and insert additional data in operation and maintenance manual when need for such data becomes apparent during instruction.

END OF SECTION
(Attachment 01 77 00-1 follows)

